

ITEM NO.	PART NO.	DESCRIPTION	QTY.
1	A304982-SL	SHELL LAYOUT FOR 8" TANK	1
2	H10511	.094 MIN. 8" O.D. 2:1 ELLIP. JOG. HEAD	2
3	F10250	1/2"-NPT FLAT FLANGE	2
4	F31840	3/4"-NPT FLAT FLANGE	4
5	F10370	1"-NPT FLAT FLANGE	1
6	A88144	ANGLE BRACKET	2
7	A20910	ASME DATA PLATE	1
8	S36195	DECAL 1X3 CAUTION TIGHTEN	1

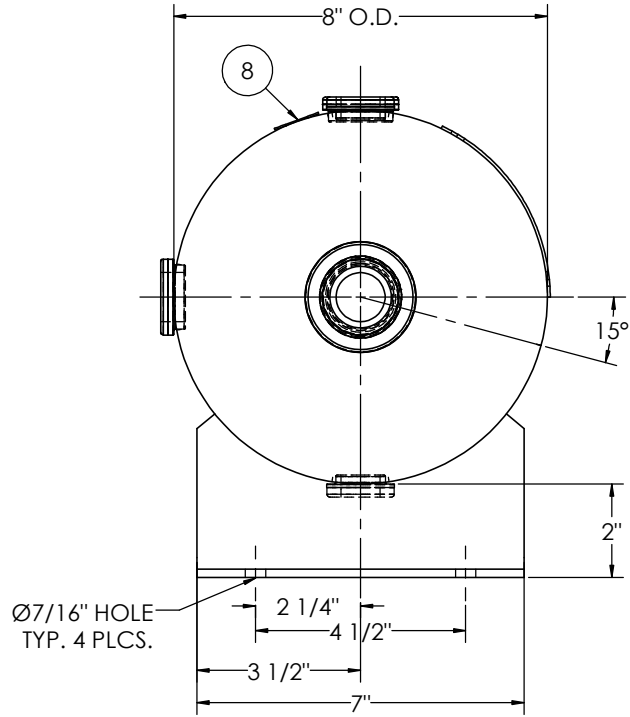

NOTES:
 1. ALL PLUGS TO BE LOOSENED TO HAND TIGHT PLUS ONE QUARTER TURN WITH WRENCH PRIOR TO SHIPMENT.

SPECIFICATIONS	
O.D. 8 LGTH. 16	MAWP 200 PSI @ 400°F
WT. 19 LBS.	
S.A. 3.0 SQ.FT.	
GAL. 3.0 CU.FT. 0.40 CRN: H9635.5123467890	W
CODE: ASME Section VIII, Div.1, LATEST EDITION	EXMT UG20(f) CORR ALW 0 SH 0 HD
STD. TOLERANCES: M-2461 (UNLESS OTHERWISE NOTED)	WELD DETAILS: M-1932

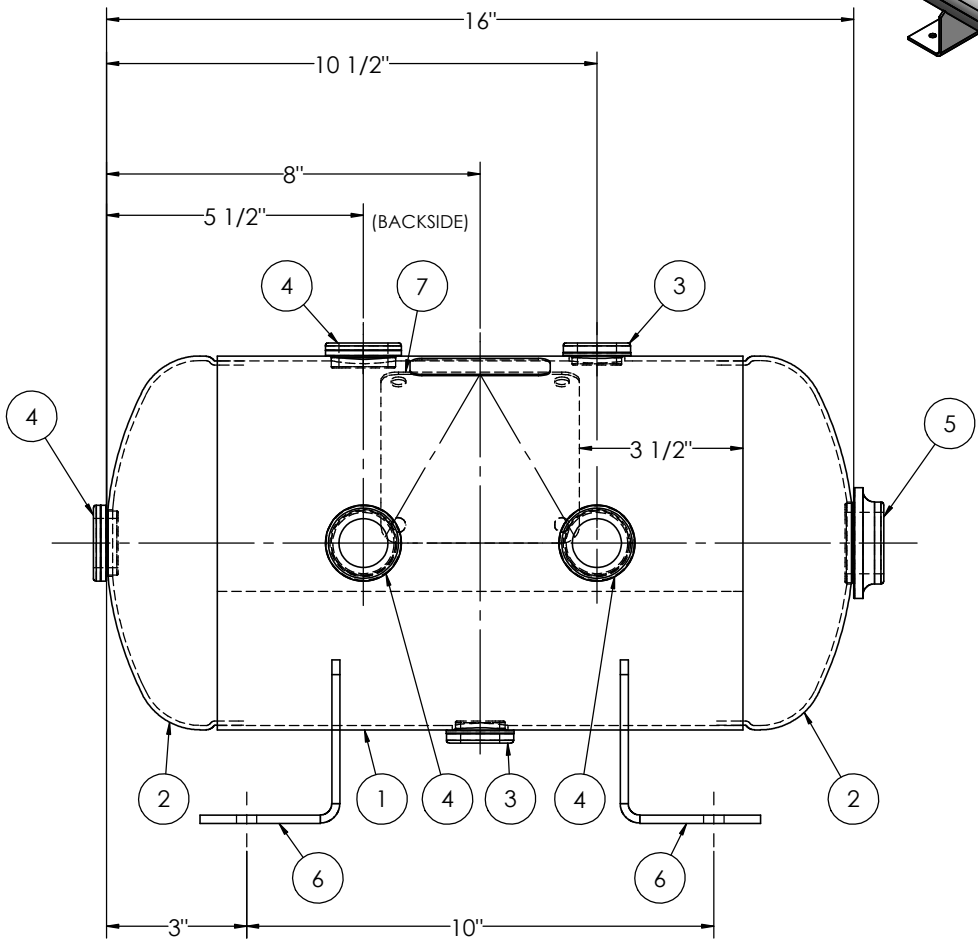

HORIZONTAL AIR RECEIVER

RELEASED FOR PRODUCTION
 Q.C. _____ DATE _____

REVISIONS			
REV.	BY	DESCRIPTION	DATE
A	EGB		
B	MK		
C	UG		

DRAWN BY: EGB	DATE:
APPR. BY: EGB	DATE:
SCALE: NONE	DRWG NO. 304982

