

ITEM NO.	PART NO.	DESCRIPTION	QTY.
1	A304932-SL	SHELL LAYOUT FOR 10" O.D. TANK	1
2	H11001	.094 MIN. 10" O.D. 2:1 ELLIP. JOG. HEAD	2
3	F31840	3/4"-NPT FLAT FLANGE	4
4	F10250	1/2"-NPT FLAT FLANGE	2
5	F10370	1"-NPT FLAT FLANGE	1
6	A84496	BRACKET ANGLE	2
7	A20910	ASME DATA PLATE	1
8	S36195	DECAL 1X3 CAUTION TIGHTEN	1

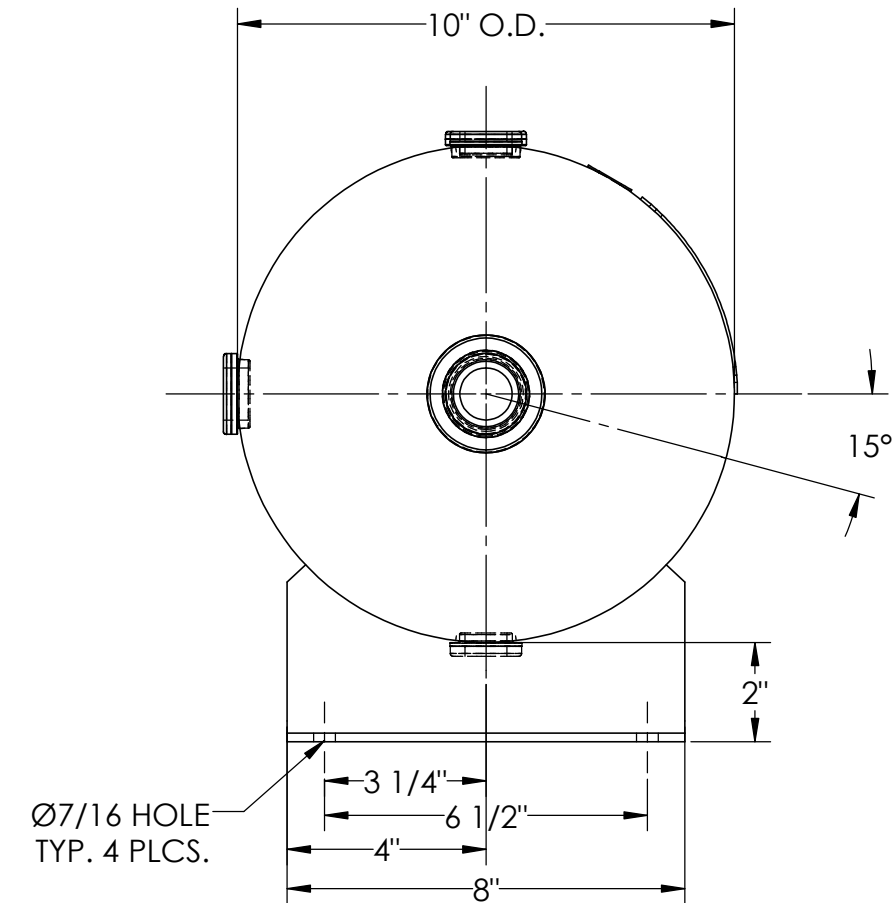
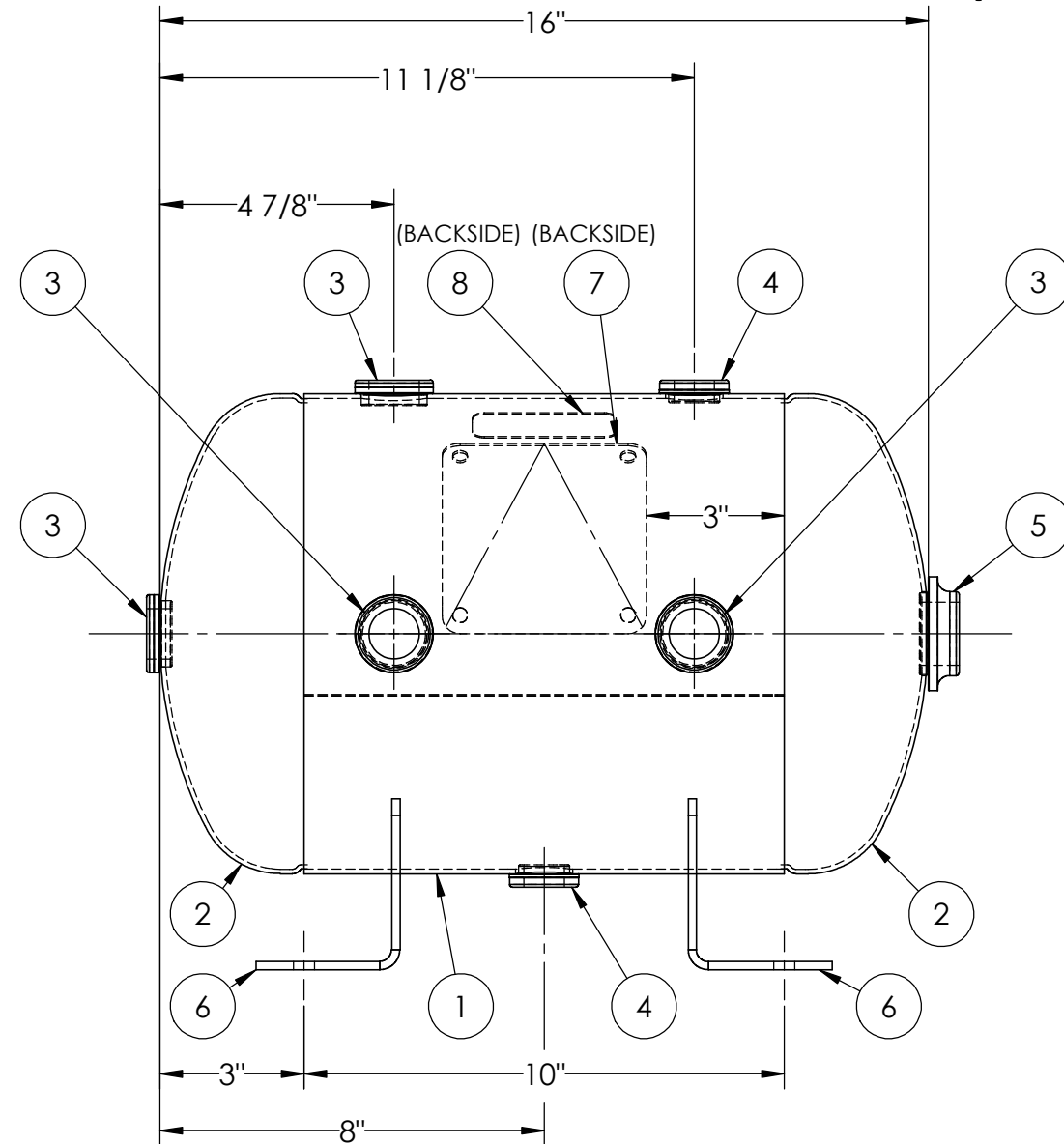

NOTES:

1. ALL PLUGS TO BE LOOSNED TO HAND TIGHT PLUS ONE QUARTER TURN WITH WRENCH PRIOR TO SHIPMENT.

SPECIFICATIONS

O.D. 10 LGTH. 16 MAWP 200 PSI @ 400°F
 WT. 22 LBS.
 S.A. 3.8 SQ.FT.
 GAL. 4.6 CU.FT. 0.62 CRN: F2150.1C
 CODE: ASME Section VIII, Div. 1, LATEST EDITION EXMT UG20(f) CORR ALW 0 SH 0 HD
 STD. TOLERANCES: M-2461 (UNLESS OTHERWISE NOTED) WELD DETAILS: M-1932



HORIZONTAL AIR RECEIVER

RELEASED FOR PRODUCTION
 Q.C. _____ DATE _____



REVISIONS			
REV.	BY	DESCRIPTION	DATE
A	EGB		
B	MK		
C	UG		

DRAWN BY:	EGB	DATE:	
APPR. BY:	EGB	DATE:	
SCALE:	NONE	DRWG NO.	304932