

ITEM NO.	PART NO.	DESCRIPTION	QTY.
1	302464-SL	SHELL LAYOUT FOR 12" TANK	1
2	H12451	.094 MIN. 12" O.D. 2:1 ELLIP. JOG. HEAD	2
3	F31826	1/4"-NPT FLAT FLANGE	1
4	F10250	1/2"-NPT FLAT FLANGE	3
5	F31840	3/4"-NPT FLAT FLANGE	2
6	A21150.1	DEFIANCE FOOT H1011X	4
7	A88700	10GA TOPPLATE	1
8	A20910	ASME DATA PLATE	1

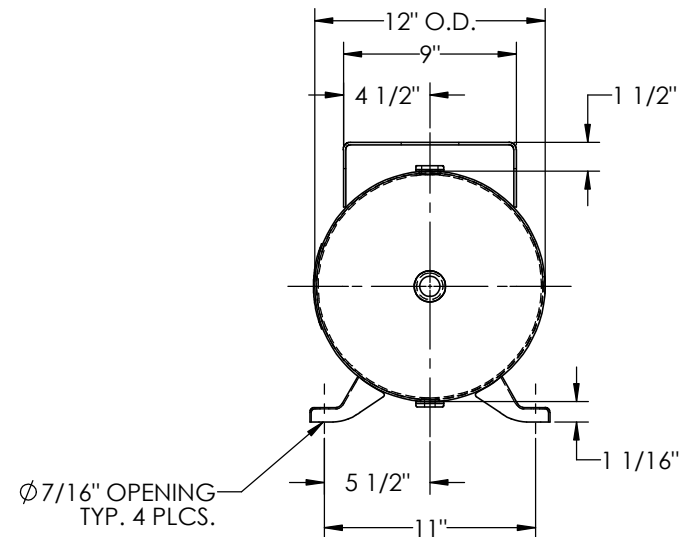
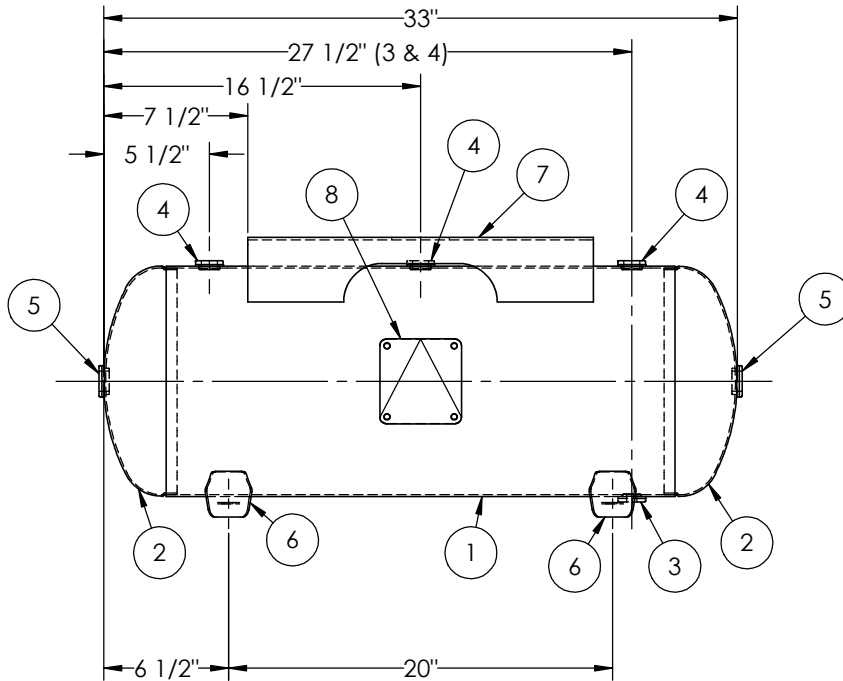

NOTES:

SPECIFICATIONS	
O.D. 12 LGTH. 33	MAWP 200 PSI @ 400°F
WT. 54 LBS.	
S.A. 9.1 SQ.FT.	
GAL. 15 CU.FT.2	CRN: F1144.1C
CODE: ASME Section VIII, Div.1, LATEST EDITION	W
STD. TOLERANCES: M-2461 (UNLESS OTHERWISE NOTED)	EXMT UG-20(f) CORR ALW 0 SH 0 HD
	WELD DETAILS: M-1932

MANCHESTER TANK

HORIZONTAL AIR RECEIVER

FILE LOCATION: O:\SolidWorks\3000\302464

DRAWN BY: _____ DATE: _____

APPR. BY: _____ DATE: _____

SCALE: NONE

DRWG NO. **302464**

RELEASED FOR PRODUCTION
Q.C. _____ DATE _____

REVISIONS			
REV.	BY	DESCRIPTION	DATE
A	NS		

APPR. BY: _____ DATE: _____

SCALE: NONE

DRWG NO. **302464**