

ITEM NO.	PART NO.	DESCRIPTION	QTY.
1	302461-SL	SHELL LAYOUT FOR 10" O.D. TANK	1
2	H11001	.094 MIN. 10" O.D. 2:1 ELLIP. JOG. HEAD	2
3	F31840	3/4"-NPT FLAT FLANGE	2
4	F10250	1/2"-NPT FLAT FLANGE	3
5	F31826	1/4"-NPT FLANGE	1
6	A21150.1	DEFIANCE FOOT H1011X	4
7	A84487	10GA TOPPLATE	1
8	A20910	ASME DATA PLATE	1

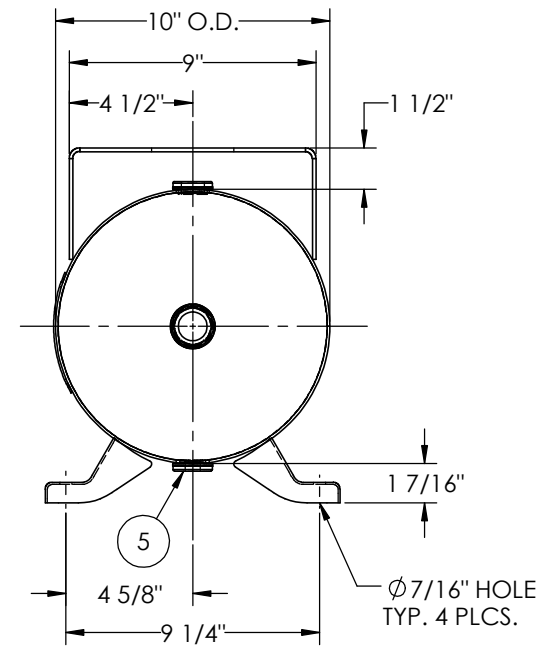

NOTES:

SPECIFICATIONS	
O.D. 10 LGTH. 30	MAWP 200 PSI @ 400°F
WT. 42 LBS.	
S.A. 6.9 SQ.FT.	
GAL. 10 CU.FT. 1.2 CRN: F2150.1C	
CODE: ASME Section VIII, Div.1, LATEST EDITION	W
STD. TOLERANCES: M-2461 (UNLESS OTHERWISE NOTED)	EXMT UG20(f) CORR ALW 0 SH 0 HD
	WELD DETAILS: M-1932

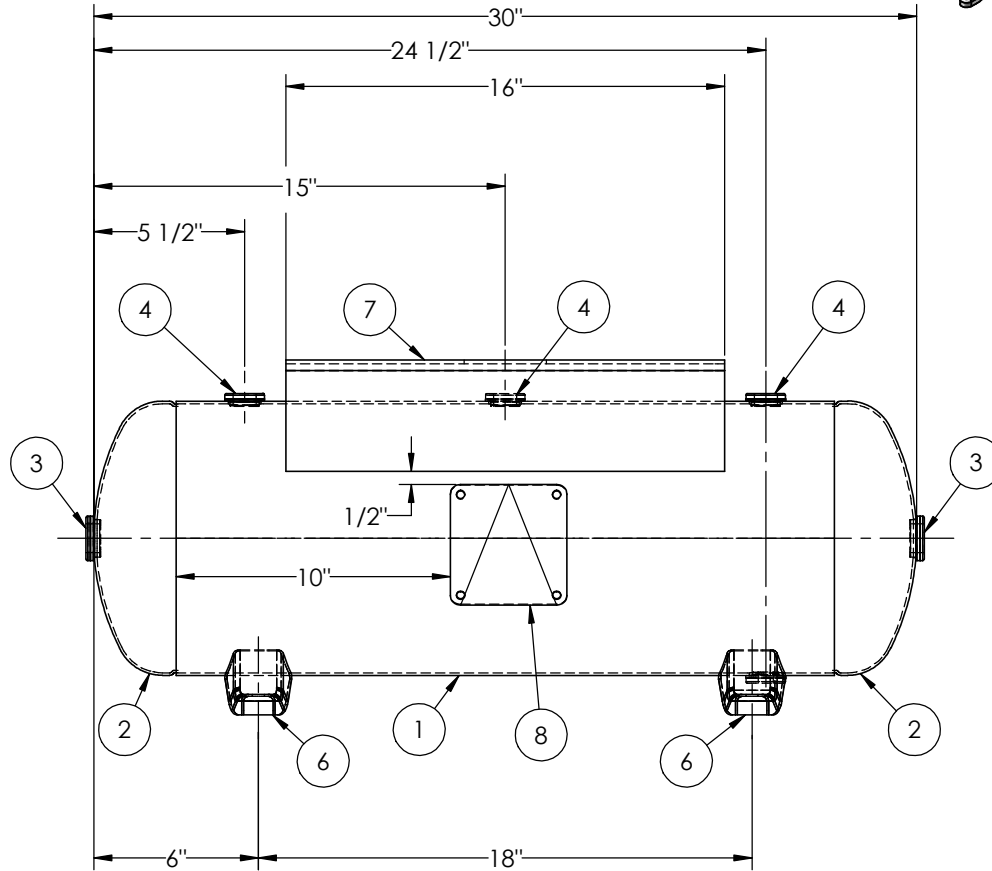

HORIZONTAL AIR RECEIVER

RELEASED FOR PRODUCTION

Q.C. _____ DATE _____

REVISIONS			
REV.	BY	DESCRIPTION	DATE
A	EGB		
B	CJ		
C	DS		
D	RK		

DRAWN BY: EGB	DATE:
APPR. BY: JR	DATE:
SCALE: NONE	DRWG NO. 302461

