

CODE/ADDENDA 2010/2011A APPROVED DP
 RELEASED FOR PRODUCTION
 Q.C. _____ DATE _____

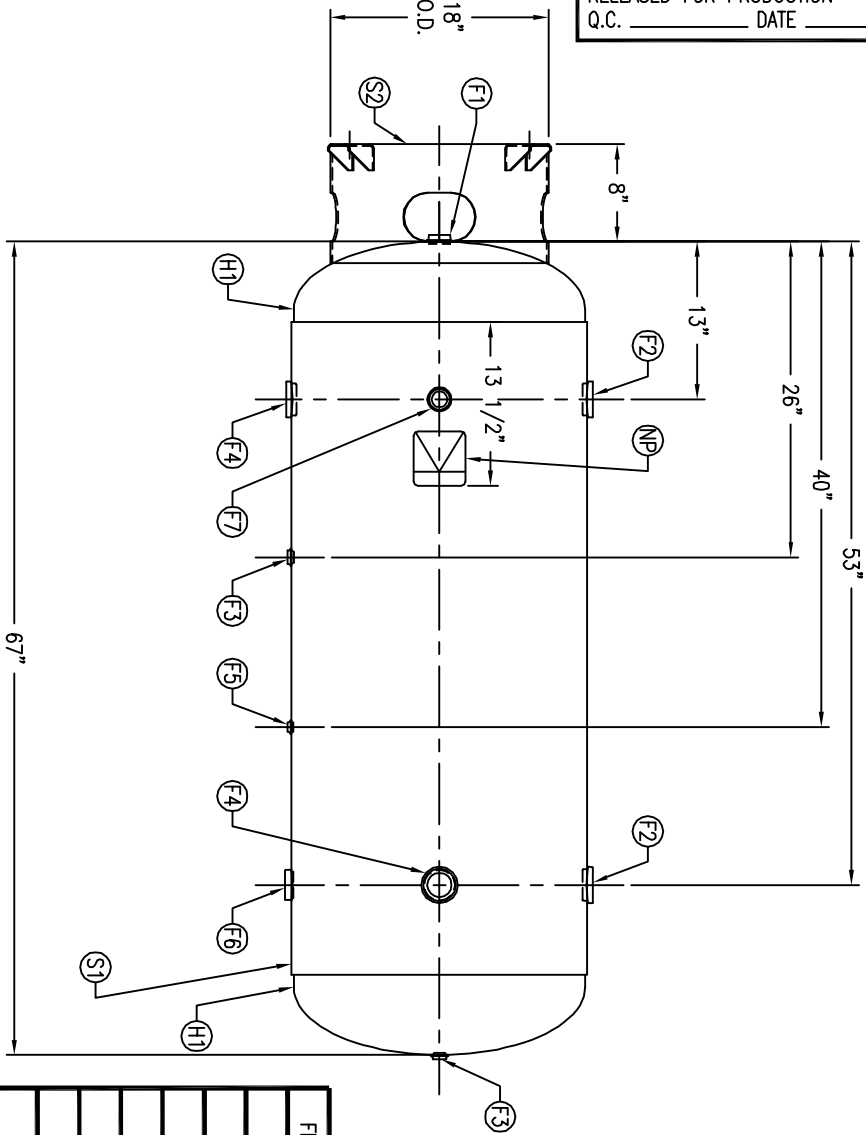

FIND NO.	NPT SIZE
F1	1
F2	2
F3	1/2
F4	2
F5	1/4
F6	1-1/2
F7	1

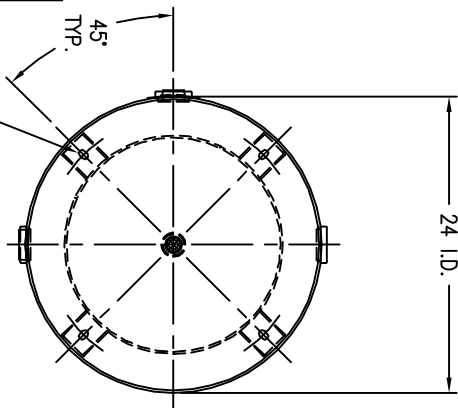

9/16" X 7/8" SLOTS
 TYP. 4 PLCS. 90° APART
 ON A 21" DIA. BOLT CIRCLE

SYM	DATE	BY	REVISION	APP	XREF	REV.	NOTES	SPECIFICATIONS
B		TA		MR				I.D. 24 LGTH. 67 SH. HD.
C		EGB		TA				MAMP 200 PSI @ 400 °F
D		EGB		MR				RT- MDMT-20 °F @ 200 PSI
E		LB		LB				EXMT TEST PSI
F		TA		TA				CRN E7400.2C
G		BMK		DP				WELD DETAILS: M-1932

		\\INTERTRN\APP\3\DWG\302\	
VERTICAL AIR RECEIVER			
DRAWN BY EGB	DATE	SCALE: NONE	DRAWING NO. 302421
APP. BY EGB	DATE		
STD. TOLERANCES (UNLESS OTHERWISE NOTED): M-2461			