

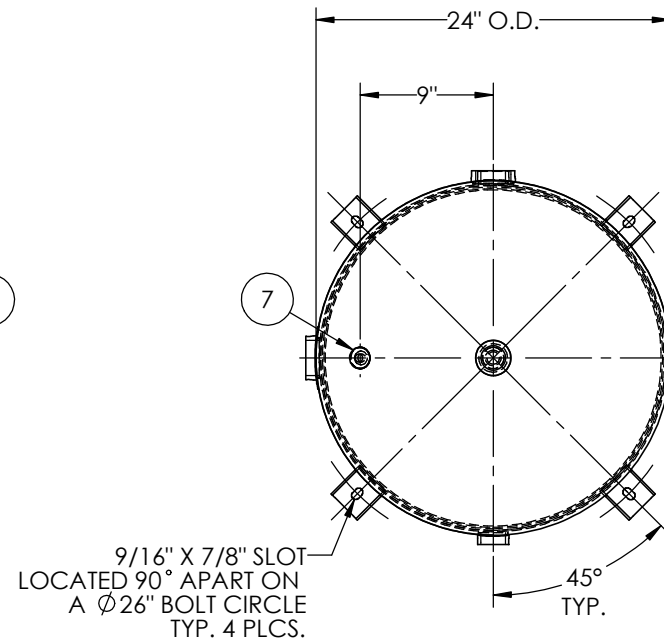

ITEM NO.	PART NO.	DESCRIPTION	QTY.
1	302418-SL	SHELL LAYOUT FOR 24" TANK	1
2	H44754	.285 MIN. 24" O.D. 2:1 ELLIP. JOG. HEAD	2
3	F30318	2"-NPT RADIAL FLANGE O-RING	2
4	F12520	1 1/4"-NPT RADIAL FLANGE	2
5	F10360	1 1/4"-NPT FLAT FLANGE	1
6	F10250	1/2"-NPT FLAT FLANGE	1
7	F31826	1/4"-NPT FLAT FLANGE	1
8	A99373	12GA BASERING ASY	1
9	A20910	ASME DATA PLATE	1

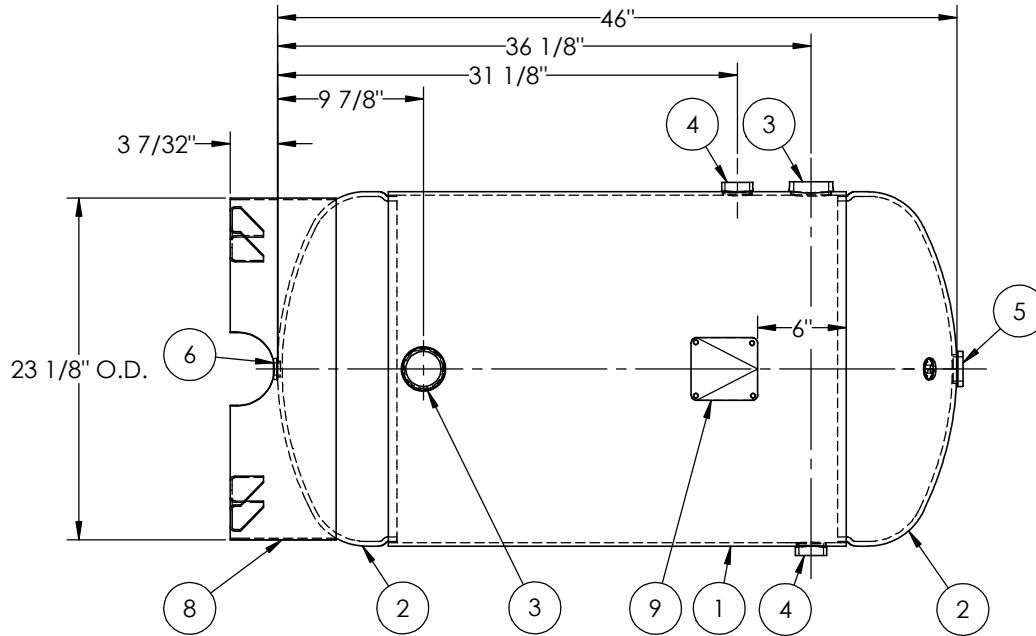

NOTES:

RELEASED FOR PRODUCTION
Q.C. _____ DATE _____

REV.		BY	REVISIONS		DATE	APP.
			DESCRIPTION			
A		EGB				EGB
B		EGB				TA
C		BC				BC
D		LG				DS

SPECIFICATIONS

O.D. 24 LGTH. 46 MAWP 300 PSI @ 400°F
 WT. 319 LBS.
 S.A. 25.9 SQ.FT.
 GAL. 80 CU.FT.10.5 CRN: F1166.1C
 CODE: ASME Section VIII, Div.1, LATEST EDITION EXMT UG-20(f) CORR ALW 0 SH 0 HD
 STD. TOLERANCES: M-2461 (UNLESS OTHERWISE NOTED) WELD DETAILS: M-1932



VERTICAL AIR RECEIVER

DRAWN BY:	DATE:
APPR. BY:	DATE:
SCALE: NONE	DRWG NO. 302418