

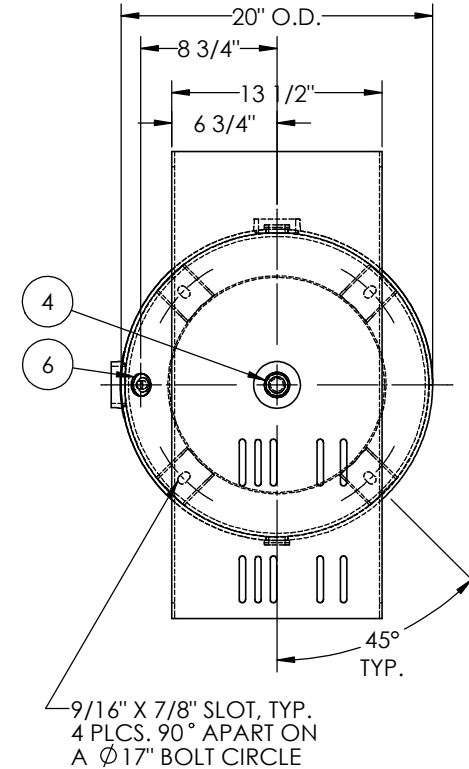

ITEM NO.	PART NO.	DESCRIPTION	QTY.
1	302413-SL	SHELL LAYOUT FOR 20" TANK	1
2	H40541	.235 MIN. 20" O.D. 2:1 ELLIP. JOG. HEAD	2
3	F30318	2"-NPT RADIAL FLANGE O-RING	2
4	F31840	3/4"-NPT FLAT FLANGE	3
5	F10250	1/2"-NPT FLAT FLANGE	1
6	F31826	1/4"-NPT FLAT FLANGE	1
7	A73116	BASERING ASY	1
8	A55916	7GA TOPPLATE	1
9	A20910	ASME DATA PLATE	1

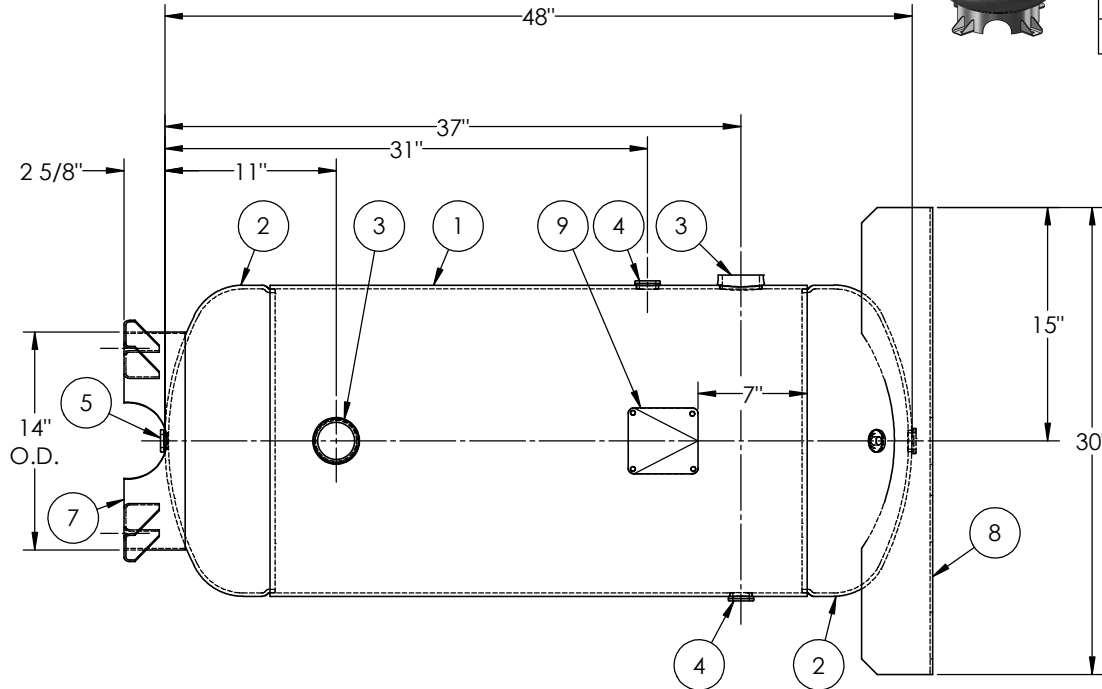

NOTES:

SPECIFICATIONS

O.D. 20 LGTH. 48
 WT. 273 LBS.
 S.A. 22.2 SQ.FT.
 GAL. 60 CU.FT.7.7 CRN: F1164.1C
 CODE: ASME Section VIII, Div.1, LATEST EDITION
 STD. TOLERANCES: M-2461 (UNLESS OTHERWISE NOTED)

MAWP 300 PSI @ 400°F
 W
 EXMT UG-20(f) CORR ALW 0 SH 0 HD
 WELD DETAILS: M-1932



VERTICAL AIR RECEIVER

FILE LOCATION: O:\SolidWorks\3000\302413

DRAWN BY: DATE:

APPR. BY: DATE:

SCALE: NONE
 DRWG NO. 302413

RELEASED FOR PRODUCTION
 Q.C. _____ DATE _____

REV.		BY	DESCRIPTION	DATE	APP.
A	EGB				TA
B	BC				BC

