

CODE/ADDENDA APPROVED
 RELEASED FOR PRODUCTION
 Q.C. _____ DATE _____

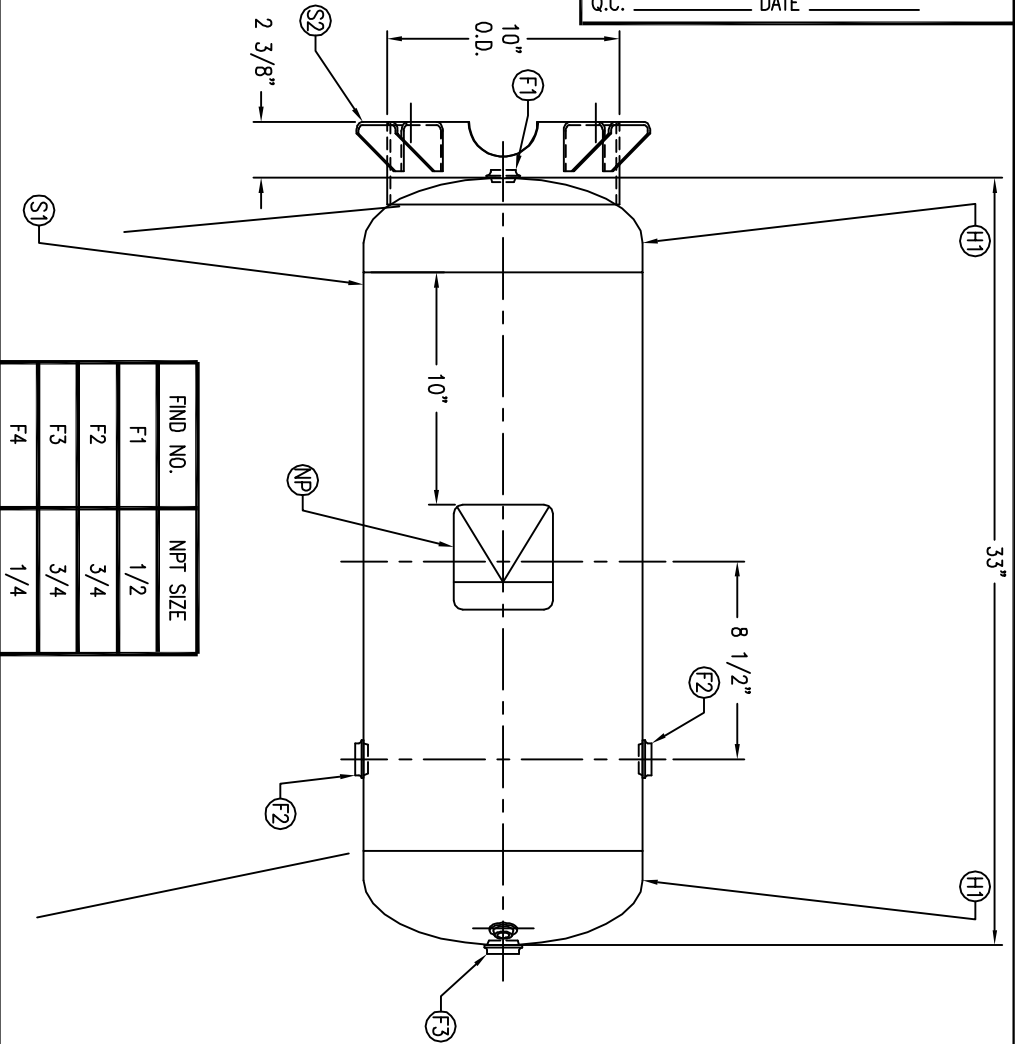

FIND NO.	NPT SIZE
F1	1/2
F2	3/4
F3	3/4
F4	1/4

SYM	DATE	BY	REVISION
A		EGB	
B		EGB	

APP	XREF	REV.
EGB	C989	B
EGB	C988	

NOTES

SPECIFICATIONS

O.D. 12 LGTH. 33 SH. MAT'L
 MAMP 300 PSI @ 650 F HD. MAT'L
 RT- MDMT -20 F @ 300 PSI GAL. 15 S.A. 9.1
 EXMT TEST PSI WT. 60# CU.F.T. 2.0
 CRN H8368.1234567890 CORR ALW SH HD
 WELD DETAILS: M-1932
 STD. TOLERANCES (UNLESS OTHERWISE NOTED): M-2461

LATEST EDITION & ADDENDA
 CODE: ASME SEC. VIII DIV. 1

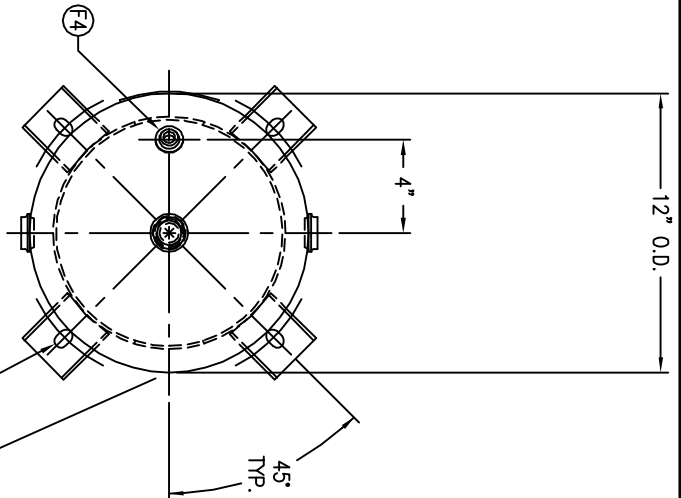

9/16" X 7/8" SLOT
 ON A 12 3/4" BOLT
 CIRCLE, TYP. 4 PLCS.



m:\cfd\trn\apps\302\DWG\302

VERTICAL AIR RECEIVER

DRAWN BY	DATE	SCALE	NONE
EGB		DRAWING NO.	302403
APP. BY	DATE		
MR			