

## ASME "Bottom Feed" Bladder Expansion Tanks

### Features

- Removable and replaceable heavy-duty butyl rubber bladder
- "Full Acceptance" for larger expanded fluid volumes
- ASME constructed and stamped
- Maximum Design Pressure 125 PSI
- Maximum Design Temperature 240°F

### Options

- Higher working pressures
- Epoxy coated and stainless steel covers
- Seismic mounting clips
- "Bulls Eye Sight Glass"

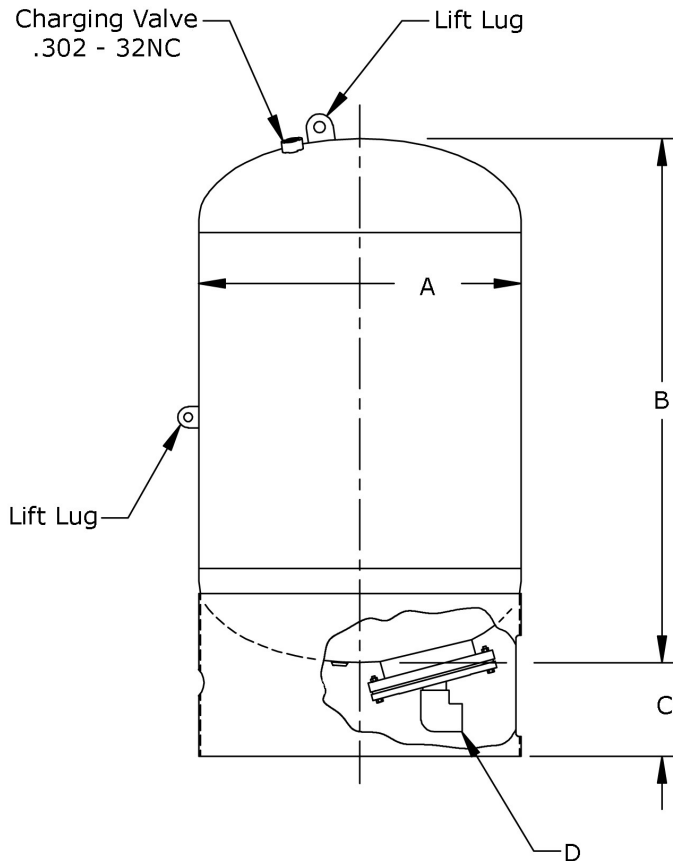

### Full Acceptance

Part Number	Tank Volume	A	B	C	D	Shipping Weight
	Gallons					
303129	36	20	30	10	2	220
303529	57	20	46	10	2	315
302761	82	24	47	12	2	350
302762	120	24	67	12	2	425
303309	165	30	59	12	2	485
303173	220	30	77	12	2	615
303159	271	36	67	12 5/8	3	815
303389	324	36	79	12 5/8	3	965
303689	377	36	91	12 5/8	3	1045
303174	440	48	64	14	3	1405
303175	550	48	78	14	3	1675

**Phone: 800-399-5628**

**www.mantank.com**