

CODE/ADDENDA _____ APPROVED _____
 RELEASED FOR PRODUCTION
 Q.C. _____ DATE _____

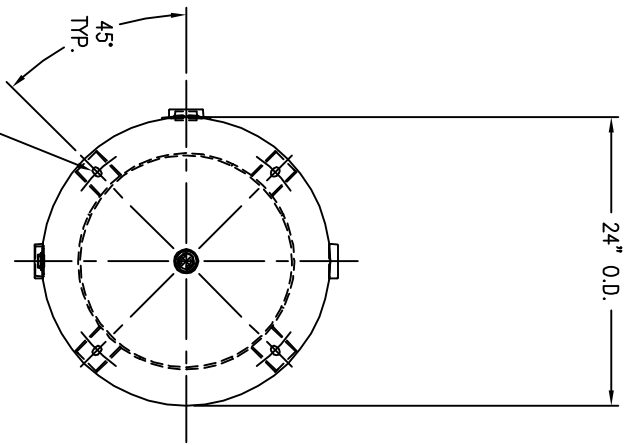
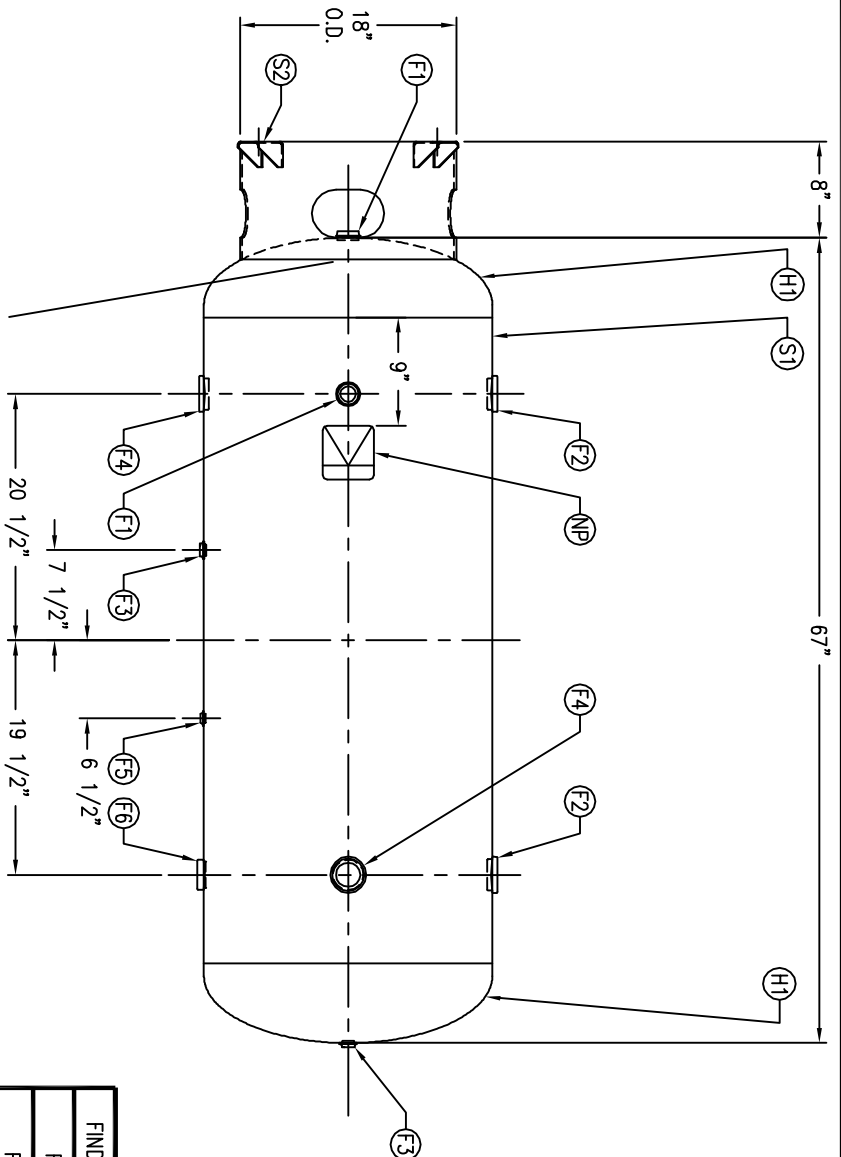

FIND NO.	NPT SIZE
F1	1
F2	2
F3	1/2
F4	2
F5	1/4
F6	1-1/2

SPECIFICATIONS

O.D. 24	LGTH. 67	SH.	MAT'L
MAMP 300 PSI @ 650 F	HD.	MAT'L	
RT- MDMT -20 F @ 300 PSI	GAL. 117.4	S.A. 36.9	
EXMT U620(f) TEST W	WT. 379#	CUF.T. 16.7	
CRN F1166.1C	CORR ALW	SH	HD
WELD DETAILS: M-1932	PER DATE OF DWG/LAST REV		
STD. TOLERANCES (UNLESS OTHERWISE NOTED): M-2461			

SWM	DATE	BY	REVISION
A		EGB	
B		TA	
C		EGB	
D		CDH	
E		JC	

APP	XREF	REV	NOTES
EGB	C1040	A	
MR			
TA			
JR			
JC			

MANCHESTER
PIPE & FABRICTION

Q:\3000\

VERTICAL AIR RECEIVER

SCALE: NONE
 DRAWING NO. 302422

DRAWN BY	DATE	SCALE
EGB		NONE
APP. BY	DATE	DRAWING NO.
MR		302422