

## ASME Plain Steel Expansion Tanks

### Features

- ASME constructed and stamped
- Design pressures:  
12" - 20" Diameter 150 psi, test 225 psi  
24" - 30" Diameter 125 psi, test 188 psi
- Leak-Proof, each tank individually tested
- Accurately positioned openings
- Manufacturer's Data Report for Pressure Vessels, Form U-1A available upon request

### Options

- Complete accessory package available; liquid level sight glass, tank fittings & drainer
- Galvanized coating
- Saddles for horizontal installation
- Custom sizes, pressures & materials available

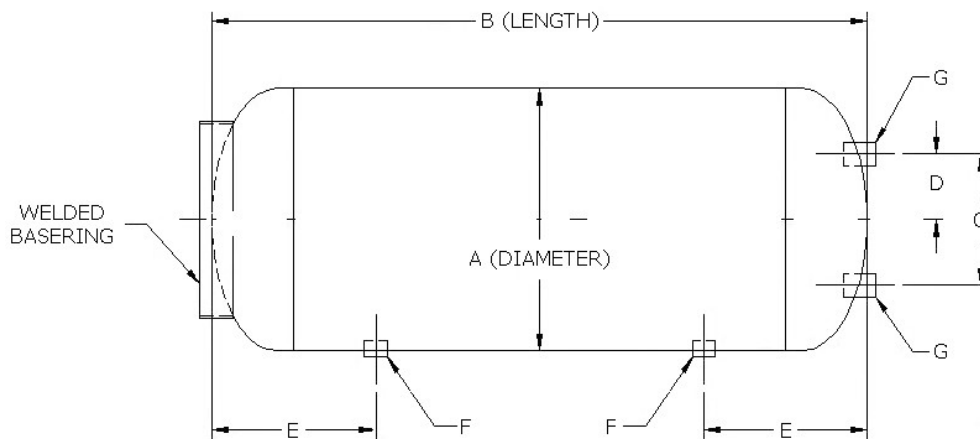

DESCRIPTION		DIMENSIONS					OPENINGS (NPT)		SHIPPING WEIGHT (LBS)	
Part #	Gallons	A	B	C	D	E	F	G	Painted	Galvanized
302537	15	12"	33"	8"	4"	7 3/4"	1"	1/2"	46	51
302538	24	12"	51"	8"	4"	7 3/4"	1"	1/2"	64	71
302539	30	14"	48"	10"	5"	8 1/2"	1"	1/2"	67	75
302540	40	14"	63"	10"	5"	9 1/4"	1"	1/2"	85	95
302541	60	16"	72"	12"	6"	10"	1"	1/2"	115	129
303167	80	20"	62 1/4"	16"	8"	10"	1"	1/2"	134	149
302542	100	20"	78"	16"	8"	11 1/8"	1"	1/2"	166	185
302543	120	24"	65"	20"	10"	11 1/8"	1"	1/2"	199	219
302544	135	24"	72"	20"	10"	13 1/2"	1 1/2"	1/2"	219	239
302545	180	30"	62"	22"	11"	13 1/2"	1 1/2"	1/2"	304	327
302546	220	30"	77"	22"	11"	13 1/2"	1 1/2"	1/2"	364	392
302547	240	30"	84"	22"	11"	13 1/2"	1 1/2"	1/2"	394	424
302548	300	30"	105 3/4"	22"	11"	13 1/2"	1 1/2"	1/2"	489	526
302549	400	36"	93 1/2"	28"	14"	14 3/4"	1 1/2"	1/2"	647	688
302536	500	36"	116"	28"	14"	14 3/4"	1 1/2"	1/2"	725	769

Phone: 800-399-5628

www.mantank.com