

PLAN VIEW
SCALE: 1" = 1'-0"
(TRUE ORIENTATION)

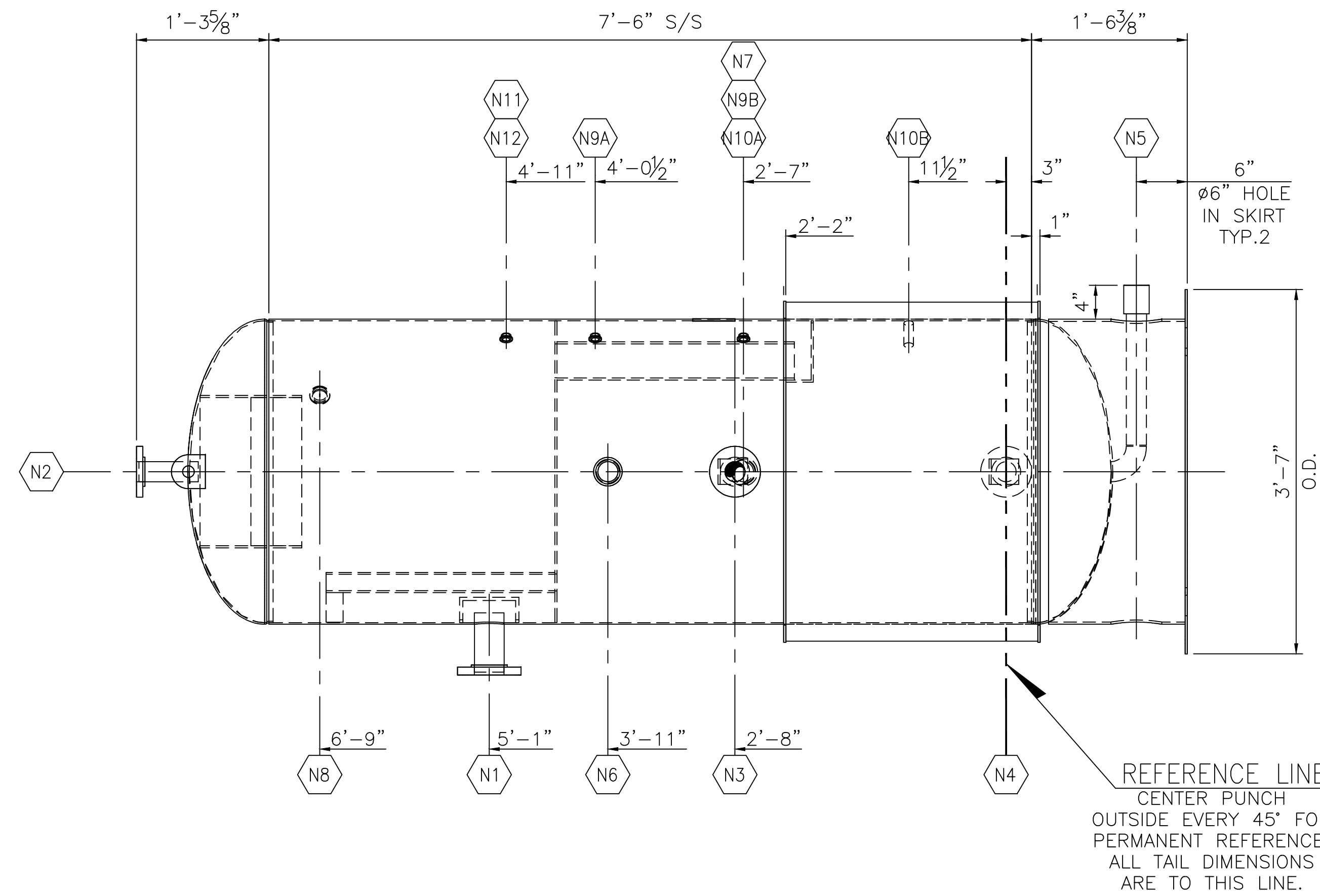

ELEVATION VIEW
SCALE 1" = 1'-0"

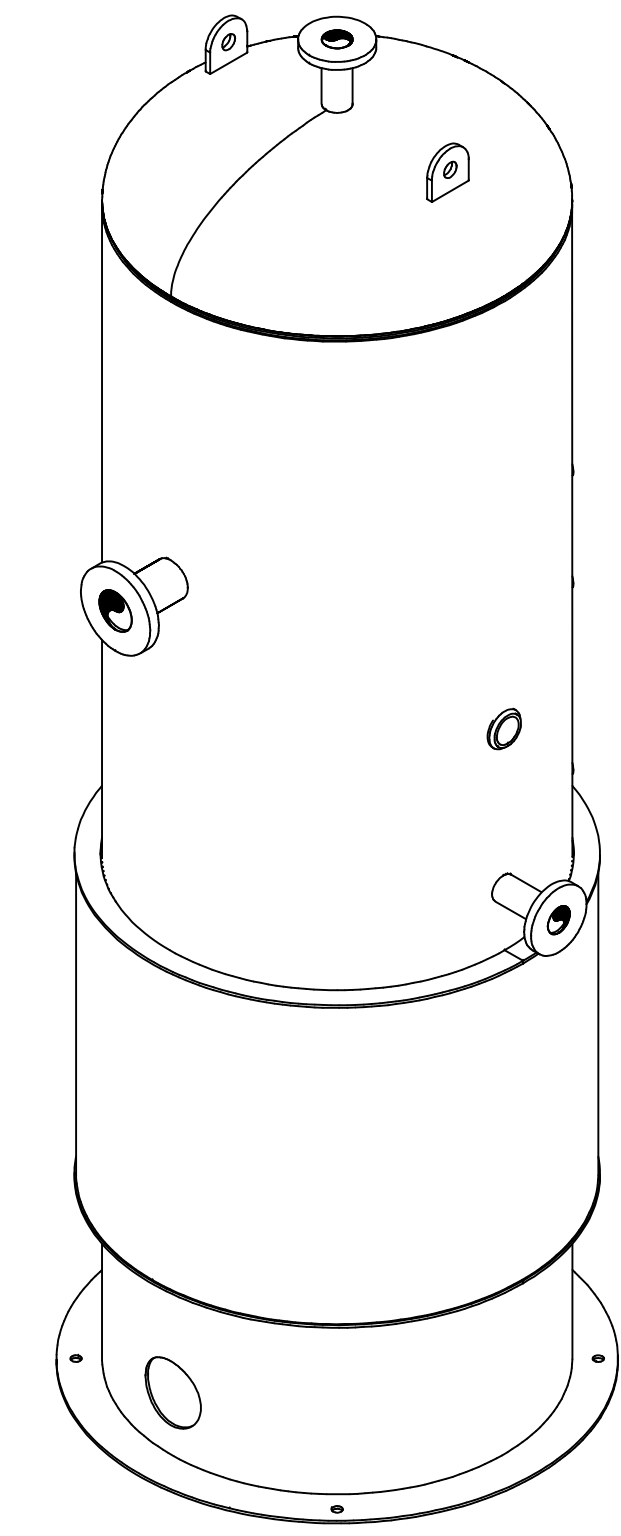

ISOMETRIC VIEW
SCALE: NONE

MARK	REQ'D.	SIZE	RATING & TYPE	SERVICE	NECK O.D.	NECK SCH.	O.S. PROJECTION	I.S.	REINF. PAD SIZE	WELDING DETAIL NO.	A	B	C
N12	1	1/2"	1500# NPT	PRESSURE TRANSMITTER	-	-	-	-	-	W13	3/16"	-	-
N11	1	1/2"	1500# NPT	TI	-	-	-	-	-	W13	3/16"	-	-
N10B	1	1/2"	3000# CPLG	GLYCOL LEVEL GAUGE	-	-	2.25"	-	-	W14	3/16"	-	-
N10A	1	1/2"	1500# NPT	GLYCOL LEVEL GAUGE	-	-	-	-	-	W13	3/16"	-	-
N9B	1	1/2"	1500# NPT	DISTILLATE LEVEL GAUGE	-	-	-	-	-	W13	3/16"	-	-
N9A	1	1/2"	1500# NPT	DISTILLATE LEVEL GAUGE	-	-	-	-	-	W13	3/16"	-	-
N8	1	1"	1500# NPT	RELIEF	-	-	-	-	-	W13	3/16"	-	-
N7	1	2"	1500# NPT	GLYCOL LLC	-	-	-	-	-	W13	3/16"	-	-
N6	1	2"	1500# NPT	CONDENSATE LLC	-	-	-	-	-	W13	3/16"	-	-
N5	1	2"	3000# CPLG	DRAIN	-	-	FLUSH	-	-	W3	1/8"	-	-
N4	1	2"	150# RFSO	GLYCOL OUTLET	2.375"	S/40	6.00"	1.00"	-	W2/W7	3/16"	-	-
N3	1	2"	150# RFSO	DISTILLATE OUTLET	2.375"	S/40	6.00"	1.00"	-	W2/W7	3/16"	-	-
N2	1	2"	150# RFSO	GAS OUTLET	2.375"	S/40	6.00"	1.00"	-	W7/W15	3/16"	3/16"	-
N1	1	3"	150# RFSO	GLYCOL INLET	2.375"	S/40	6.00"	1.00"	-	W2/W7	3/16"	-	-

NOZZLE SCHEDULE & WELDING DETAILS

NOZZLE NOTES: 1) DRILL AND TAP 1/4" N.P.T. HOLE IN REINFORCING PADS. 2) INSIDE EDGES OF NOZZLE NECKS SHALL BE ROUNDED TO 1/8" RAD. OR HALF THE WALL THICKNESS IF LESS THAN 1/4". 3) GOUGE, GRIND OR CHIP INSIDE TO SOUND METAL BEFORE MAKING WELD "b". 4) NOZZLE PROJ. ARE FROM SHORT SIDE.

NAMEPLATE DATA

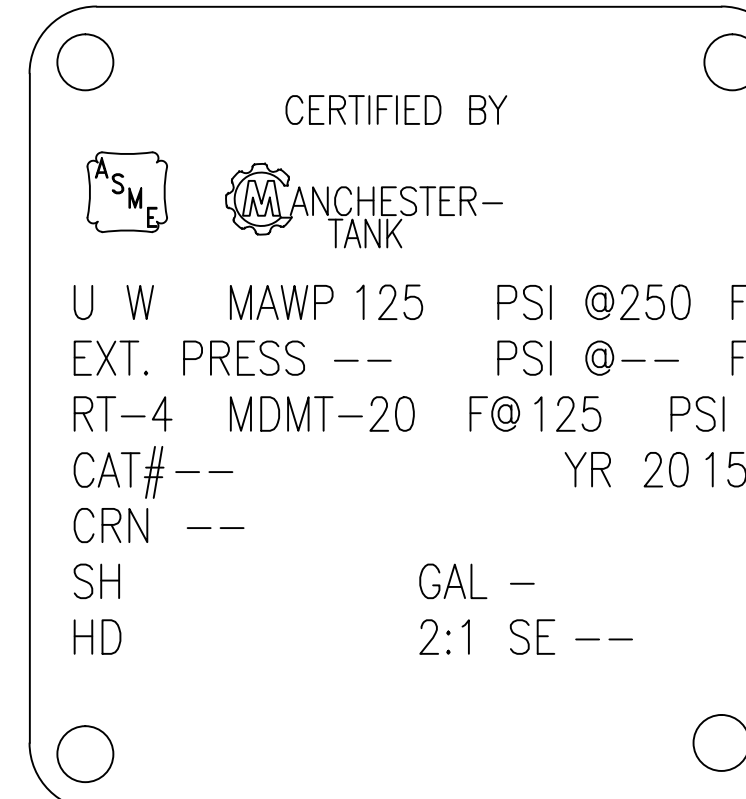

TOTAL WEIGHT = 1,200 LBS.

TOLERANCES (EXCEPT AS NOTED)
FRACTIONAL ± 1/8"
DECIMAL ± 0.125"
ANGULAR ± 1°

FABRICATION NOTES:

- UNLESS NOTED OTHERWISE, ALL WELDS ARE TO BE 3/16" FILLET WELDS.
- ALL FLANGE BOLT HOLES TO STRADDLE VESSEL CENTERLINES.
- EACH CONNECTION TO BE TAGGED W/ ABBREVIATION SERVICE DESCRIPTION



THIS DRAWING IS THE PROPERTY OF MANCHESTER TANK AND IS NOT TO BE USED FOR ANY PURPOSE OTHER THAN THAT FOR WHICH IT IS SPECIFICALLY FURNISHED.

CUSTOMER: MANCHESTER TANK
TITLE: VERTICAL GAS/GLYCOL/DISTILLATE SEPARATOR 36" OD x 7'-6" S/S @ 125 PSIG ELEVATION & PLAN VIEW

REV	DESCRIPTION	DATE	BY	CHK	SCALE	AS NOTED
A	ISSUED FOR INFORMATION	06/18/15	MCH	JEG		
REV	DESCRIPTION	DATE	BY	CHK	SCALE	AS NOTED