

PLAN VIEW
SCALE 1 1/2" = 1'-0"
CLOSURE REMOVED FOR CLARITY
(TRUE ORIENTATION)

(4) 7/8"Ø HOLES ON 2'-10"Ø B.C.
STRADDLE NORMAL CENTERLINES

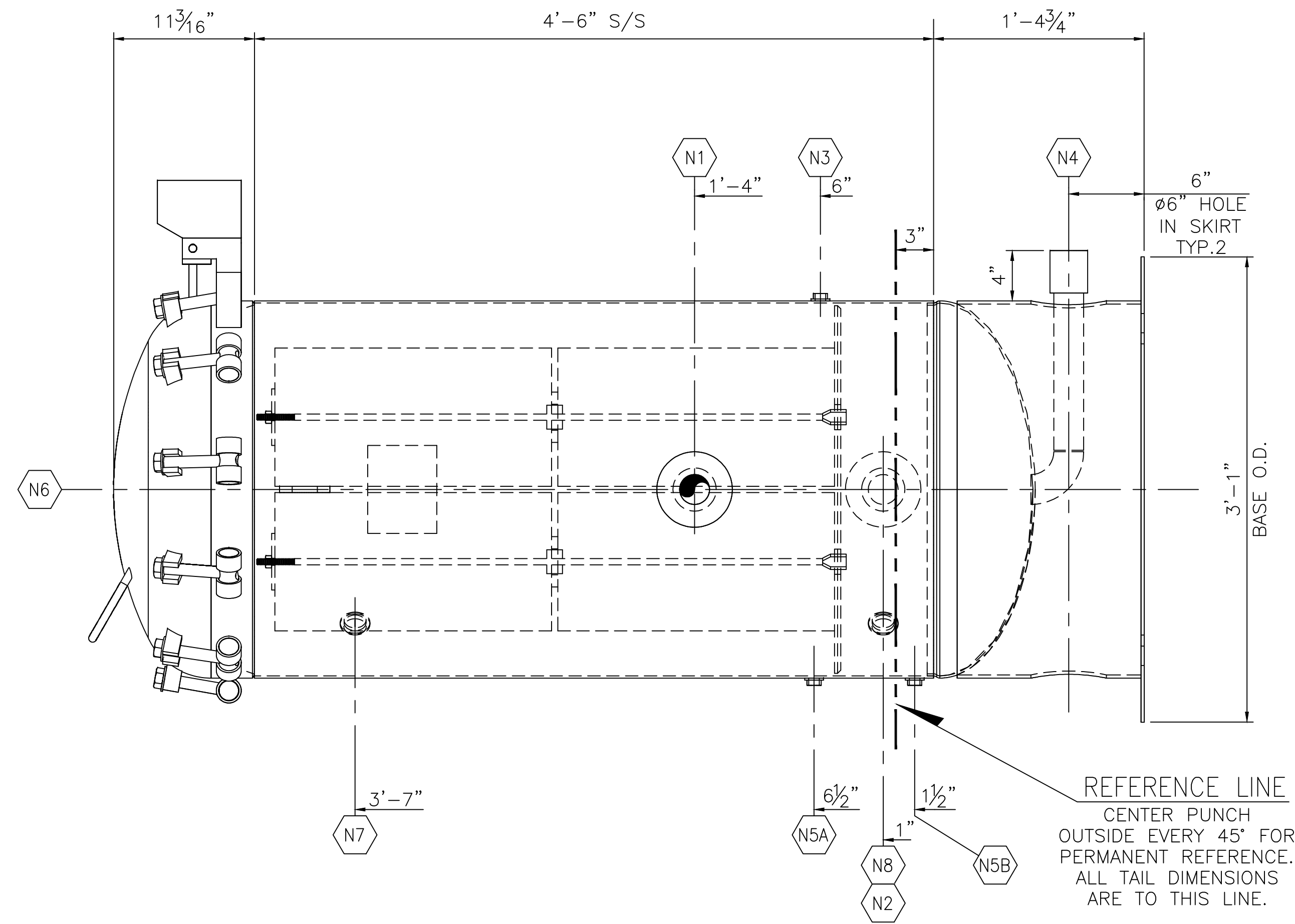

ELEVATION VIEW
SCALE 1 1/2" = 1'-0"

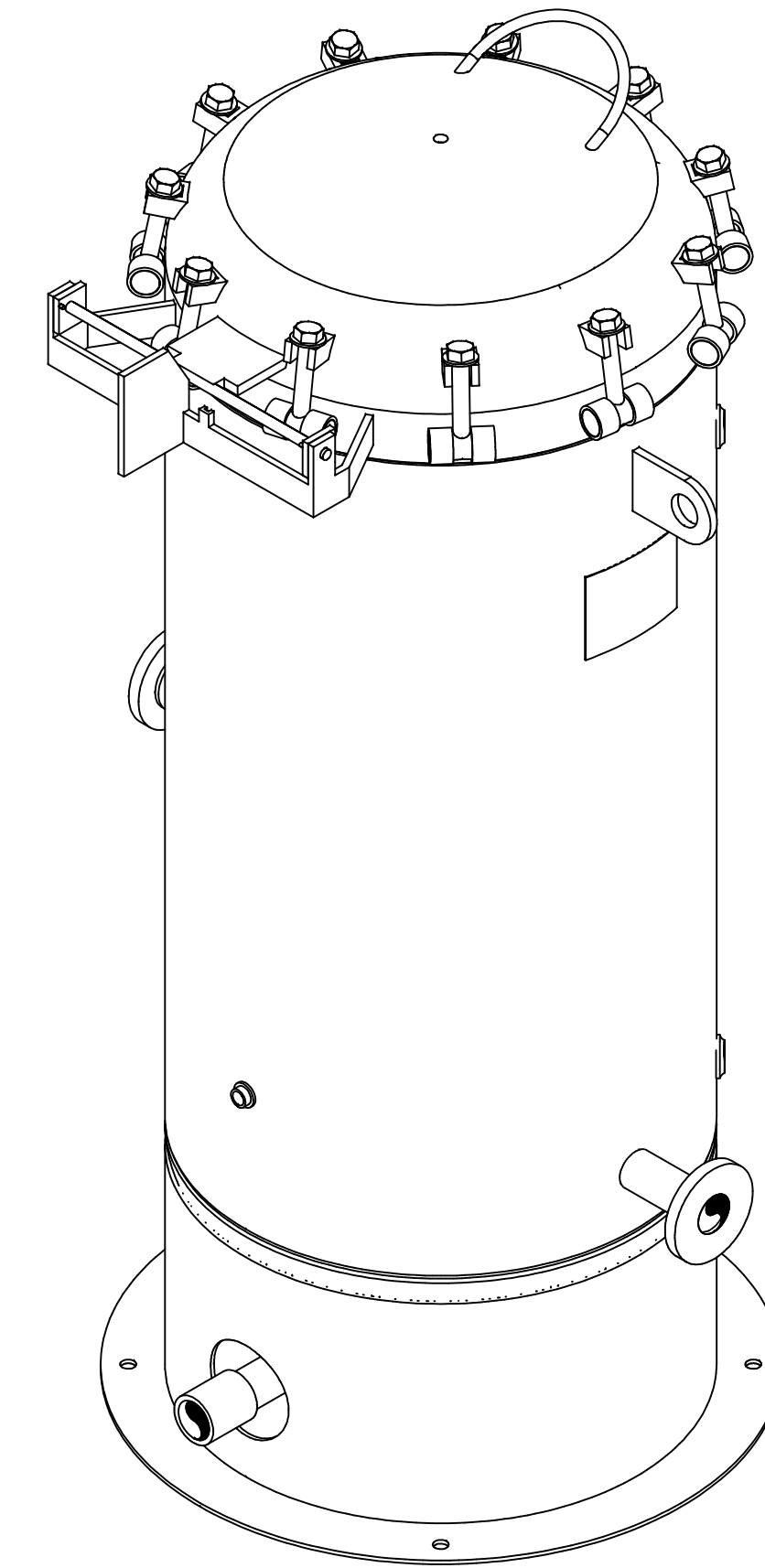

ISOMETRIC VIEW
SCALE NONE

MARK	REQ'D.	SIZE	RATING & TYPE	SERVICE	NECK O.D.	NECK SCH.	O.S. PROJECTION	I.S.	REINF. PAD SIZE	WELDING DETAIL NO.	A	B	C
N8	1	1"	1500# NPT	PSV AUX	-	-	-	-	-	W13	3/16"	-	-
N7	1	1"	1500# NPT	PSV	-	-	-	-	-	W13	3/16"	-	-
N6	1	1 1/2"	1500# NPT	VENT (PROVIDED ON CLOSURE)	-	-	-	-	-	W13	3/16"	-	-
N5B	1	1 1/2"	1500# NPT	DPI	-	-	-	-	-	W13	3/16"	-	-
N5A	1	1 1/2"	1500# NPT	DPI	-	-	-	-	-	W13	3/16"	-	-
N4	1	2"	3000# CPLG	LOWER DRAIN	-	-	-	FLUSH	-	W3	3/16"	-	-
N3	1	1 1/2"	1500# NPT	UPPER DRAIN	-	-	-	-	-	W13	3/16"	-	-
N2	1	2"	150# RFSO	OUTLET	2.375"	S/40	6.00"	1.00"	-	W2/W7	3/16"	-	-
N1	1	2"	150# RFSO	INLET	2.375"	S/40	6.00"	1.00"	-	W2/W7	3/16"	-	-

NOZZLE SCHEDULE & WELDING DETAILS

NOZZLE NOTES: 1) DRILL AND TAP 1/4" N.P.T. HOLE IN REINFORCING PADS. 2) INSIDE EDGES OF NOZZLE NECKS SHALL BE ROUNDED TO 1/8" RAD. OR HALF THE WALL THICKNESS IF LESS THAN 1/4". 3) GOUGE, GRIND OR CHIP INSIDE TO SOUND METAL BEFORE MAKING WELD "b". 4) NOZZLE PROJ. ARE FROM SHORT SIDE.

NAMEPLATE DATA

CERTIFIED BY

MANCHESTER-TANK

U W MAWP 125 PSI @250 F
EXT. PRESS -- PSI @-- F
RT-4 MDMT-20 F@125 PSI
CAT#-- YR 2015
CRN --
SH GAL 176
HD 2:1 SE --

TOTAL WEIGHT = 950 LBS.

TOLERANCES (EXCEPT AS NOTED)				
FRACTIONAL	± 1/8"			
DECIMAL	± 0.125"			
ANGULAR	± 1°			
FABRICATION NOTES:				
1. UNLESS NOTED OTHERWISE, ALL WELDS ARE TO BE 3/16" FILLET WELDS.				
2. ALL FLANGE BOLT HOLES TO STRADDLE VESSEL CENTERLINES.				
3. EACH CONNECTION TO BE TAGGED W/ ABBREVIATION SERVICE DESCRIPTION				
REV	DESCRIPTION	DATE	BY	CHK
A	ISSUED FOR INFORMATION	06/18/15	MCH	JEG

MANCHESTER TANK
SINCE 1946

THIS DRAWING IS THE PROPERTY OF MANCHESTER TANK AND IS NOT TO BE USED FOR ANY PURPOSE OTHER THAN THAT FOR WHICH IT IS SPECIFICALLY FURNISHED

CUSTOMER: **MANCHESTER TANK**

TITLE: **VERTICAL CHARCOAL FILTER**
30" OD x 4'-6" S/S @ 125 PSIG
ELEVATION & PLAN VIEW

DRW. NO.	DATE	CHK BY	DATE	SCALE
MCH	06/18/15	JEG	06/18/15	AS NOTED

REV A