

CODE/ADDENDA 2010/2011A APPROVED DP
 RELEASED FOR PRODUCTION
 Q.C. _____ DATE _____

FIND NO.	NPT SIZE
C1	3/4
C2	1/2
F1	3/4
F2	1/2
F3	1

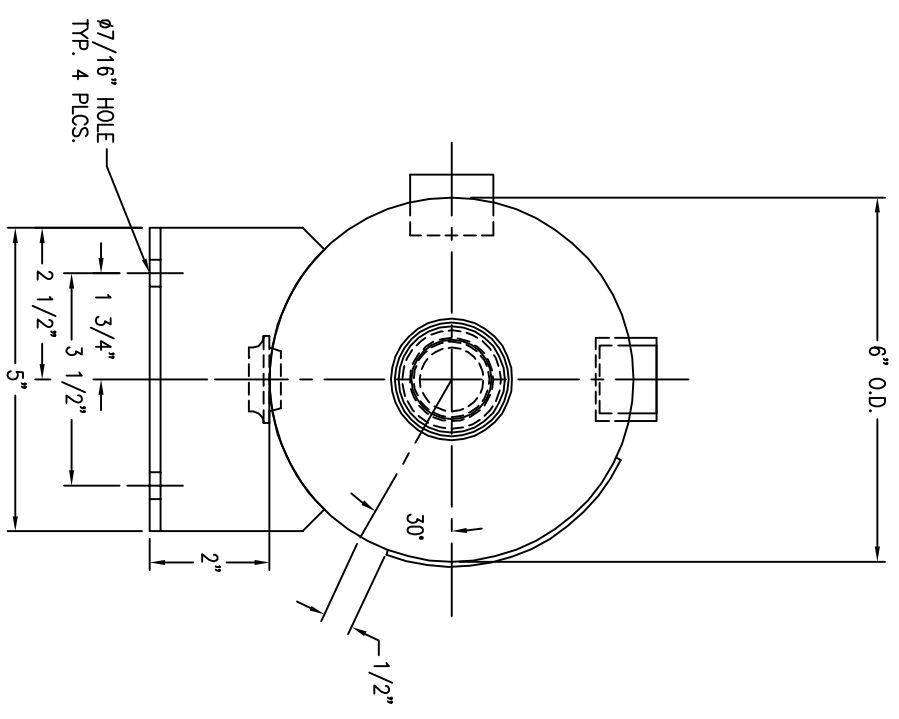
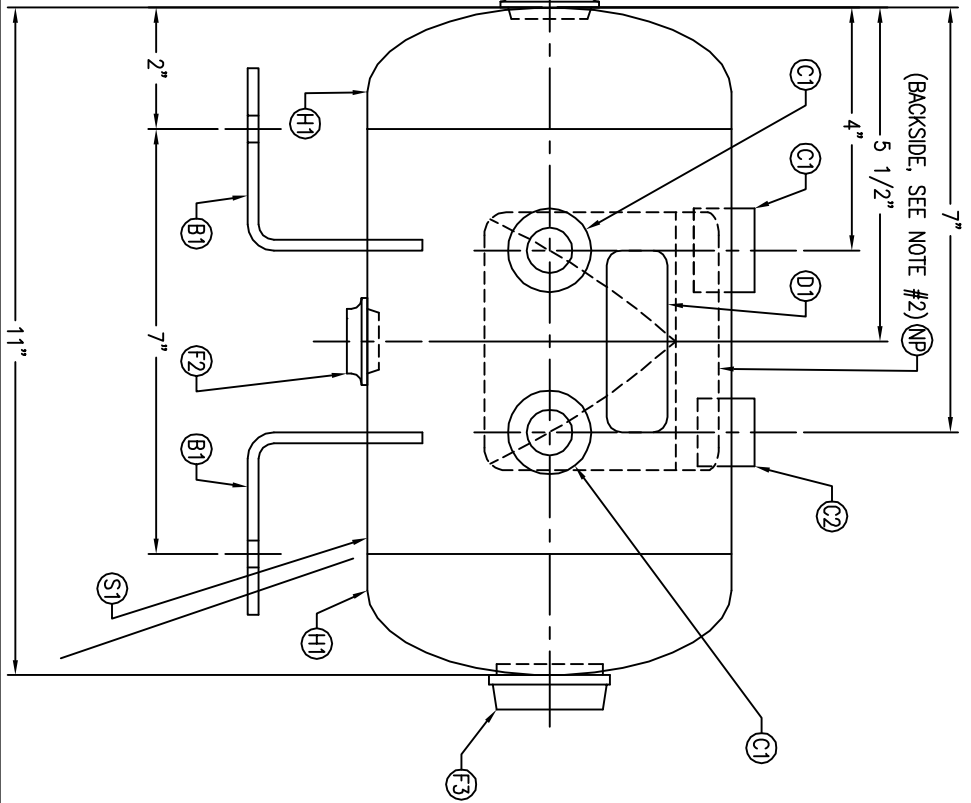

NOTES

- ALL PLUGS TO BE LOOSENED TO HAND TIGHT PLUS ONE HALF TURN PRIOR TO SHIPMENT.
- LOCATE NAMEPLATE 1/2" UP FROM LONG WELD SEAM, CENTER BETWEEN HEADS.

SYMBOL	DATE	BY	REVISION
A		MR EGB	
B		MR EGB	

APP	XREF	REV
MR	C1096	

SPECIFICATIONS	
O.D. 6	LGTH. 11
MAMP 200	PSI @ 650 F.
RT- MDMT	T@ PSI
EXMT	TEST
CRN F2188.1234567890	
SH. HD.	SA. 1.6
WT. 12#	CULFT. .16
CORR ALW	SH HD
CODE: ASME SEC. VIII DIV. I	
LATEST EDITION & ADDENDA	
WELD DETAILS: M-1932	
STD. TOLERANCES (UNLESS OTHERWISE NOTED): M-2461	

DRAWN BY		DATE	
MR EGB			

METERRAIN APPS & CAD \DWG\304

MANCHESTER

HORIZONTAL AIR RECEIVER

SCALE: NONE
 DRAWING NO. 304978