

CODE/ADDENDA 2004/2006 APPROVED KM
 RELEASED FOR PRODUCTION
 Q.C. _____ DATE _____

FIND NO.	NPT SIZE
F1	1/2
F2	3/4
F3	1 1/2
F4	2

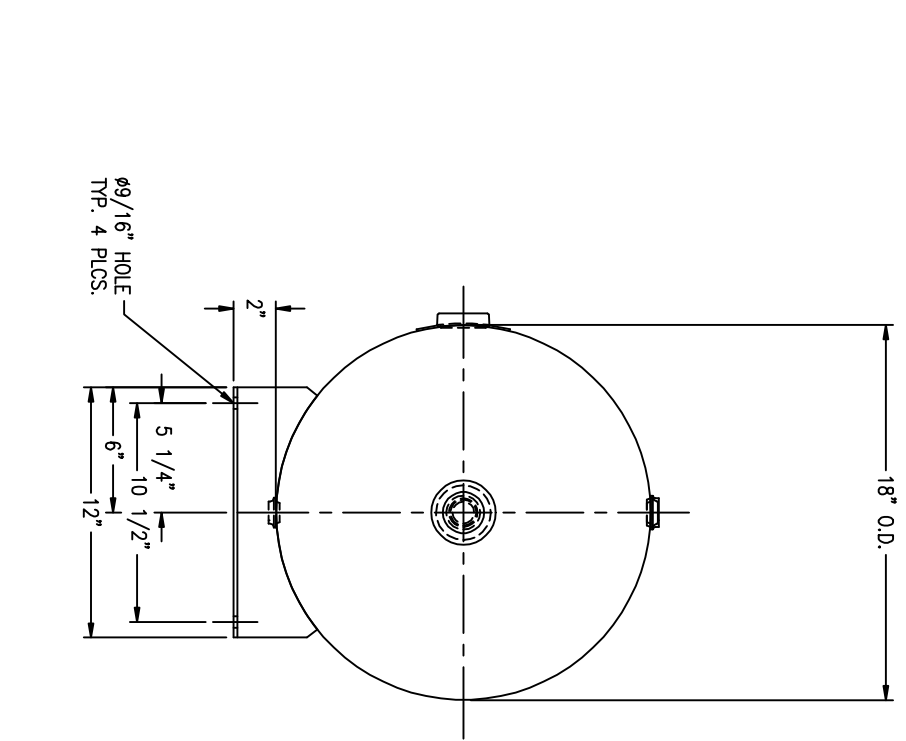
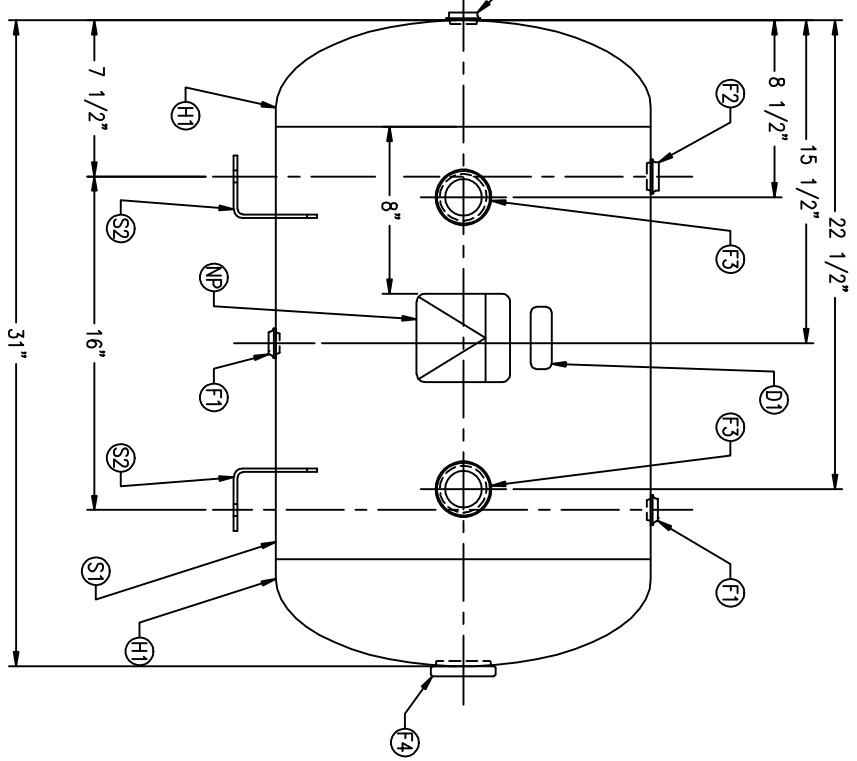

SYM	DATE	BY	REVISION

APP	XREF	REV	NOTES
	C1728		1. ALL PLUGS TO BE LOOSENED TO HAND TIGHT PLUS ONE HALF TURN PRIOR TO SHIPMENT.

SPECIFICATIONS	
O.D. 18	LGTH. 31
MAMP 200	PSI @ 650 °F
CRN H8753.1C	

QAL. 30	S.A. 13.2
WT. 97#	CULFT. 4.0
CODE: ASME SEC. VIII DIV. I, LATEST EDITION & ADDENDA	



\\CORP2\DWG\304

HORIZONTAL AIR RECEIVER

DRAWN BY	DATE	SCALE: NONE
APP. BY	DATE	DRAWING NO. 304946