

CODE/ADDENDA 2010/2011A APPROVED DP  
 RELEASED FOR PRODUCTION  
 Q.C. \_\_\_\_\_ DATE \_\_\_\_\_

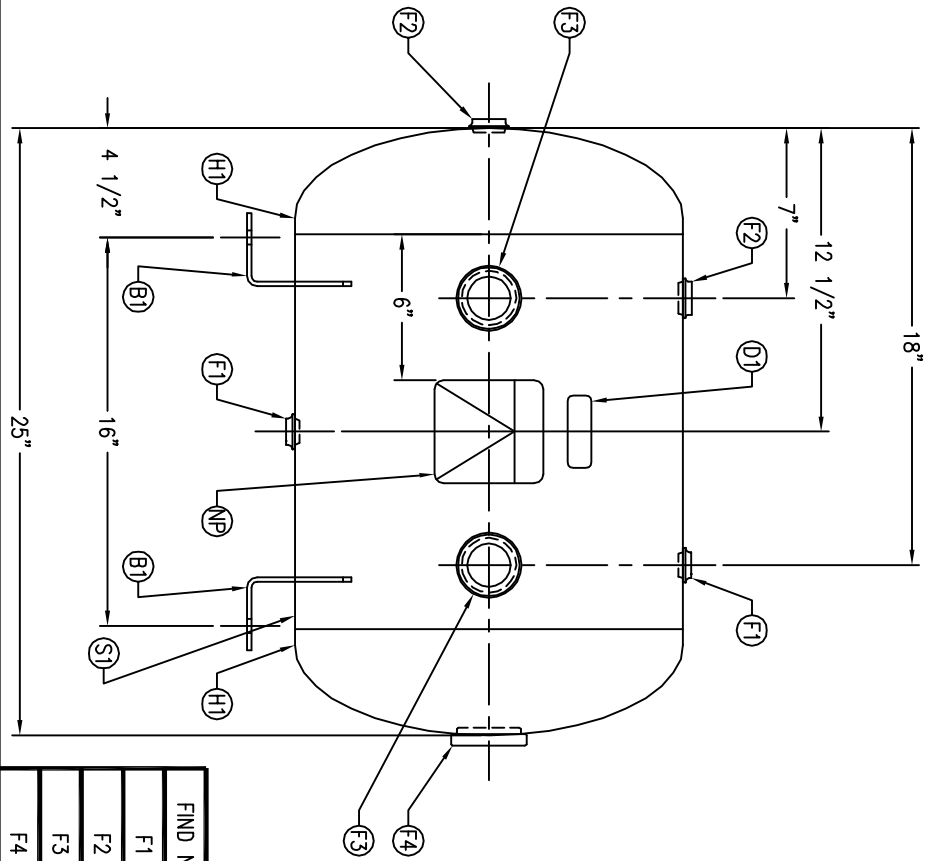

FIND NO.	NPT SIZE
F1	1/2
F2	3/4
F3	1-1/2
F4	2

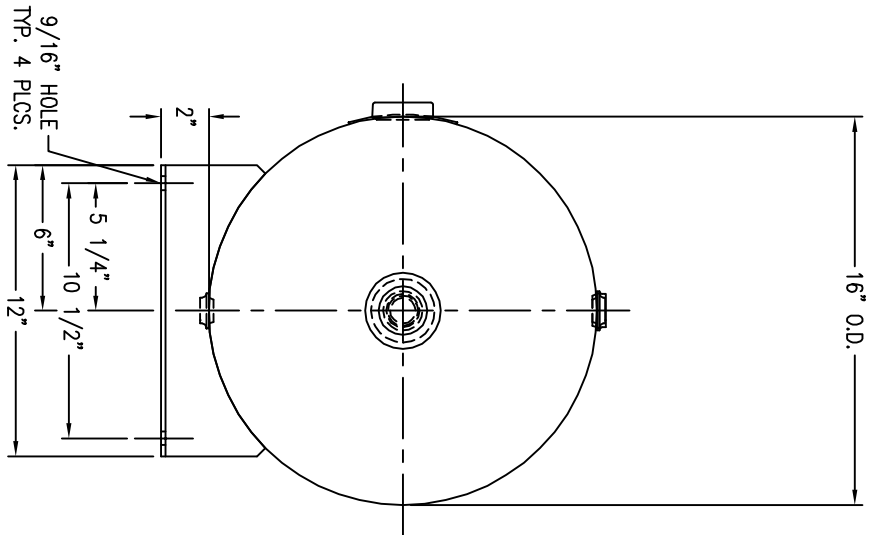

REVISION

APP XREF REV

NOTES

SPECIFICATIONS

1. ALL PLUGS TO BE LOOSENED TO HAND TIGHT PLUS ONE HALF TURN PRIOR TO SHIPMENT.

O.D. 16 LGTH. 25 SH.  
 MAMP 200 PSI @ 650 F HD.  
 RT- MDMT-20 T@ 200 PSI GAL. 18.7 S.A. 9.5  
 EXMT UG20(f) TEST PSI WT. 59# CU.FT. 2.5  
 XRAY W CORR ALW SH  
 CRN F2151.1C HD  
 WELD DETAILS: M-1932  
 STD. TOLERANCES (UNLESS OTHERWISE NOTED): M-2461

**MANCHESTER**

**HORIZONTAL AIR RECEIVER**

MITERAIN.APPPS\ACAD\DWG\304

DRAWN BY EGB	DATE	SCALE: NONE
APP. BY EGB	DATE	DRAWING NO. 304942

SYM	DATE	BY	REVISION	APP XREF REV	NOTES	SPECIFICATIONS	DRAWN BY	DATE	SCALE: NONE
A		EGB		EGB	1. ALL PLUGS TO BE LOOSENED TO HAND TIGHT PLUS ONE HALF TURN PRIOR TO SHIPMENT.	O.D. 16 LGTH. 25 SH. MAMP 200 PSI @ 650 F HD. RT- MDMT-20 T@ 200 PSI GAL. 18.7 S.A. 9.5 EXMT UG20(f) TEST PSI WT. 59# CU.FT. 2.5 XRAY W CORR ALW SH CRN F2151.1C HD WELD DETAILS: M-1932 STD. TOLERANCES (UNLESS OTHERWISE NOTED): M-2461	EGB		304942