

CODE/ADDENDA 2004/2006 APPROVED KM
 RELEASED FOR PRODUCTION
 Q.C. _____ DATE _____

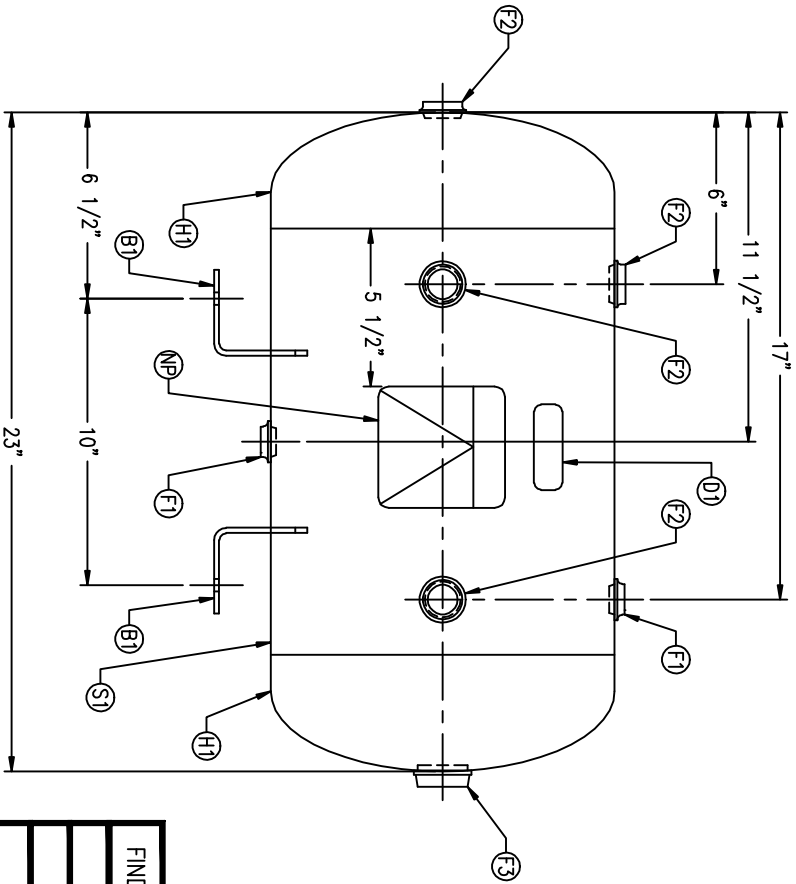

FIND NO.	NPT SIZE
F1	1/2
F2	3/4
F3	1

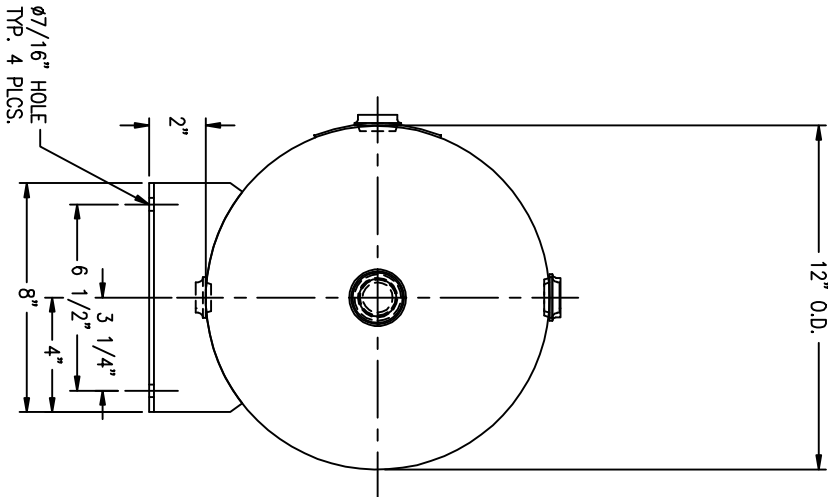

SYMBOL DATE BY

REVISION

APPX REF REV

NOTES

SPECIFICATIONS

1. INTERIOR OF TANK MUST BE INSPECTED AND CLEANED OF ALL FOREIGN PARTICULATE MATTER.
2. ALL PLUGS TO BE LOOSENED TO HAND TIGHT PLUS ONE HALF TURN PRIOR TO SHIPMENT.



MANCHESTER TANK CORP2\DWG 304

HORIZONTAL AIR RECEIVER

CRN F1144.1C
 WELD DETAILS: M-1932
 STD. TOLERANCES (UNLESS OTHERWISE NOTED): M-2461

O.D. 12 LGTH. 23
 MAMP 200 PSI @ 650 F
 SH. HD.
 GAL. 10 SA. 6.5
 WT. 34# CULFT. 1.3

CODE: ASME SEC. VIII DIV. 1,
 LATEST EDITION & ADDENDA

DRAWN BY _____ DATE _____
 APP. BY _____ DATE _____

SCALE: NONE
 DRAWING NO. 304936