

CODE/ADDENDA 2004/- APPROVED JR
 RELEASED FOR PRODUCTION
 Q.C. _____ DATE _____

FIND NO.	NPT SIZE
F1	2
F2	2
F3	1
F4	1/4

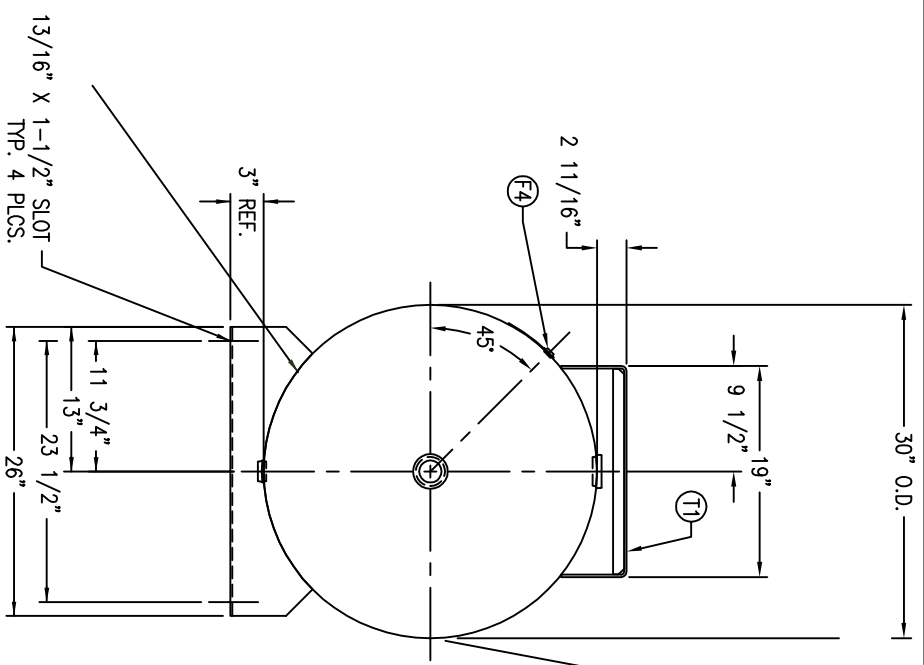
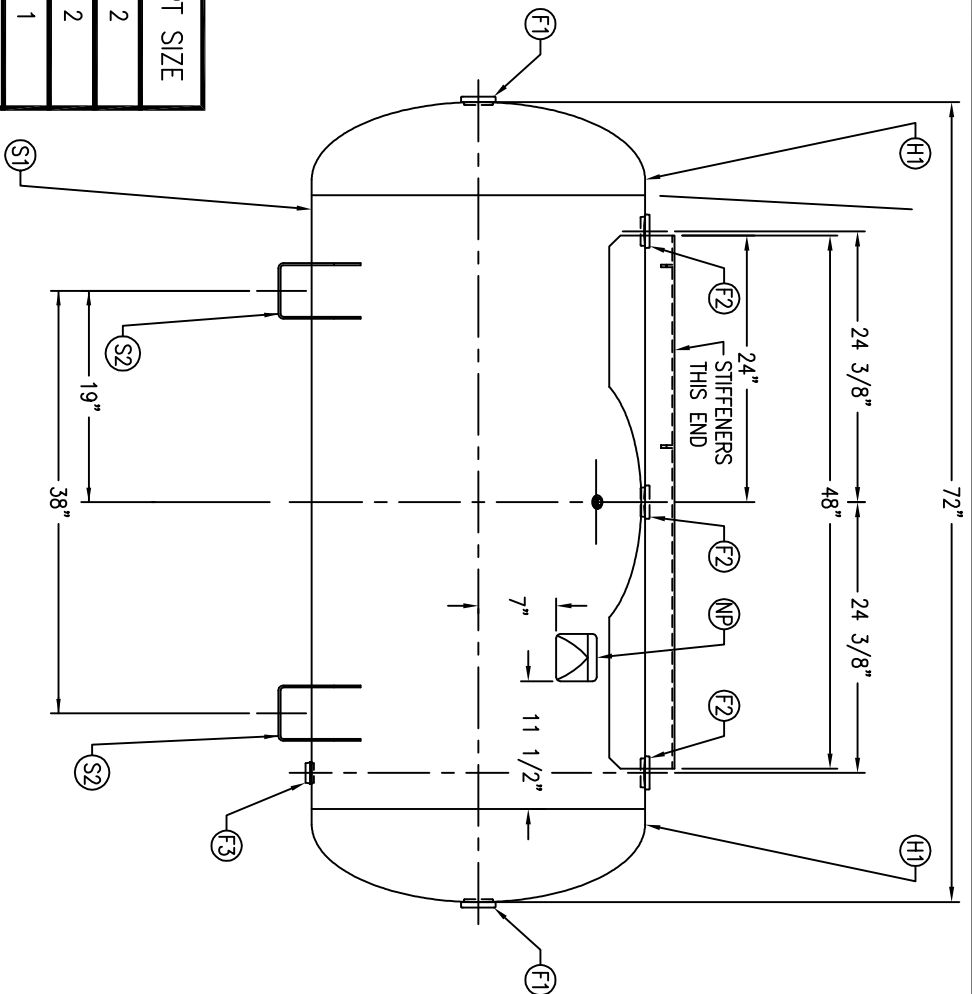

SYM	DATE	BY	REVISION	APP	XREF	REV.	NOTES

SPECIFICATIONS		NOTES	
O.D. 30	LGTH. 72	CS21	C
MAMP 200	PSI @ 650 F	CS22	
CRN F0628.1C			
GAL. 200	S.A. 50.0		
WT. 632#	CU.FT. 26.5		
CODE: ASME SEC. VIII DIV. I, LATEST EDITION & ADDENDA			
WELD DETAILS: M-1932			
STD. TOLERANCES (UNLESS OTHERWISE NOTED): M-2461			
DRAWN BY		DATE	
APP. BY		DATE	
SCALE: NONE		DRAWING NO.	
HORIZONTAL AIR RECEIVER		302483	



H:\3000\