

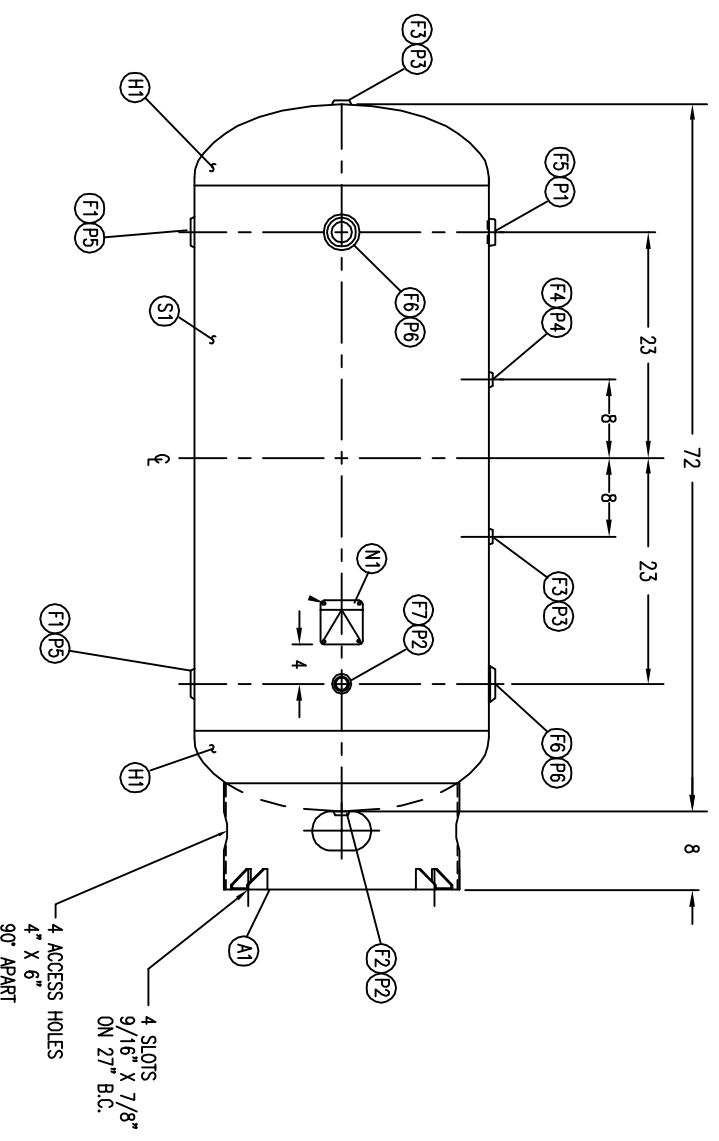

CODE/ADDENDA _____ APPROVED _____
 RELEASED FOR PRODUCTION
 Q.C. _____ DATE _____

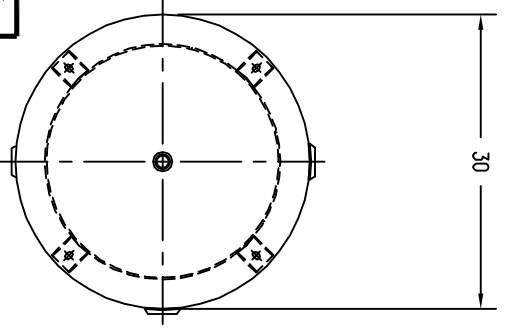

FIND NO.	NPT SIZE
F1	2
F2	1
F3	1/2
F4	1/4
F5	1-1/2
F6	2

SYMBOL	DATE	BY	REVISION	APP	NOTES	SPECIFICATIONS
A		ECB		TA		O.D.: 30 LGTH: 72 MAWP: 300 PSI @ 400° F RT MDMT - 20 F @ 300 PSI EXMT: UG 20(f) X-RAY: CRN# F1629.123456 SH: MAT'L: HD: GAL. 200 SA: 51 ft 2 WT: 735 # CUL.FT: 27 CORR ALW: SH HD CODE: ASME / NB PER DATE OF DWG/LAST REV
B		CDH		JC		
C		JC		JC		
D		JC		JC		
E		JC		JC		

WELD DETAILS M-1932
 STD. TOLERANCES (UNLESS OTHERWISE NOTED) M-2461

MANCHESTER
 VERTICAL AIR RECEIVER
 200 GALLON
 Q-1300A

DRAWN BY	DATE	SCALE: NONE
APP. BY	DATE	DRAWING NO. 302427

REF 273007200239