

CODE/ADDENDA 2010/2011A APPROVED DP
 RELEASED FOR PRODUCTION
 Q.C. _____ DATE _____

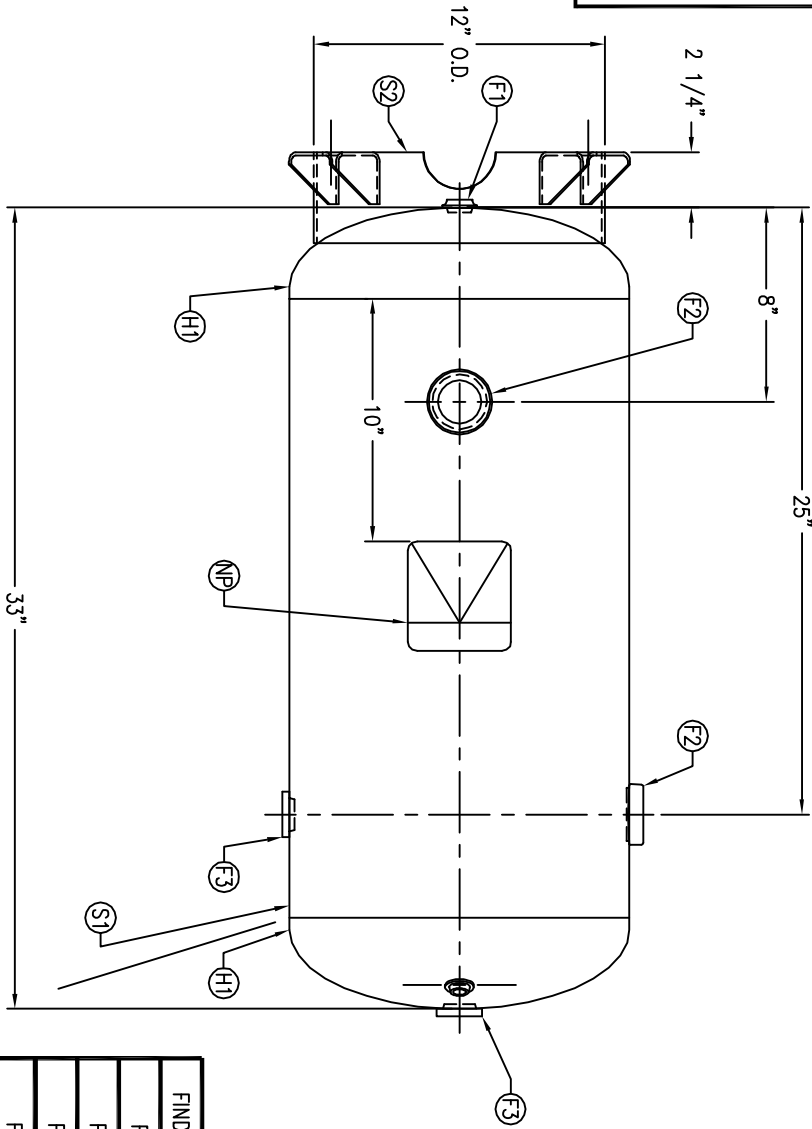

FIND NO.	NPT SIZE
F1	1/2
F2	1-1/2
F3	3/4
F4	1/4

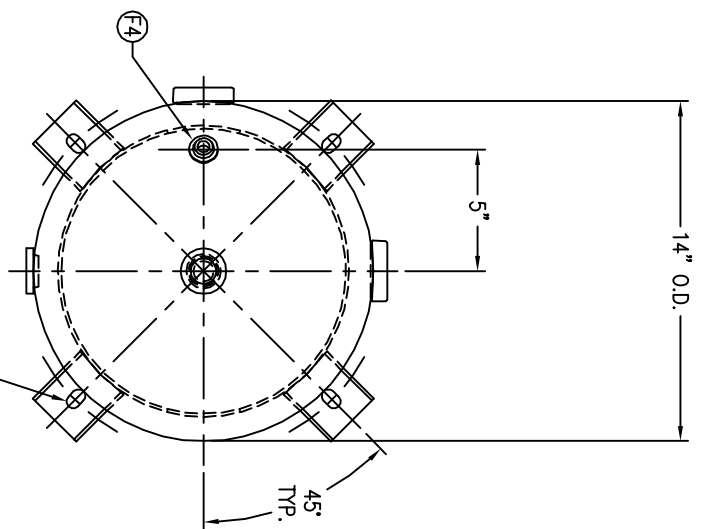

SYM	DATE	BY	REVISION	APP	XREF	REV.	NOTES
A		EGB			C1111		
B		EGB					

SPECIFICATIONS	
O.D. 14	LGTH. 33
MAWP 200	PSI @ 650 °F
RT- MDMT-20	°F @ 200 PSI
EXMT UG20(f)	TEST PSI
XRAY	W
CRN	HS605.5123467890
WELD DETAILS:	M-1932
STD. TOLERANCES	(UNLESS OTHERWISE NOTED): M-2461

DRAWN BY		DATE		SCALE: NONE	
EGB				DRAWING NO. 302404	

MANCHESTER
 \MTEPRAT\APPS\DWG\302

VERTICAL AIR RECEIVER