

LEFT END VIEW
SCALE 1" = 1'-0"
(TRUE ORIENTATION)

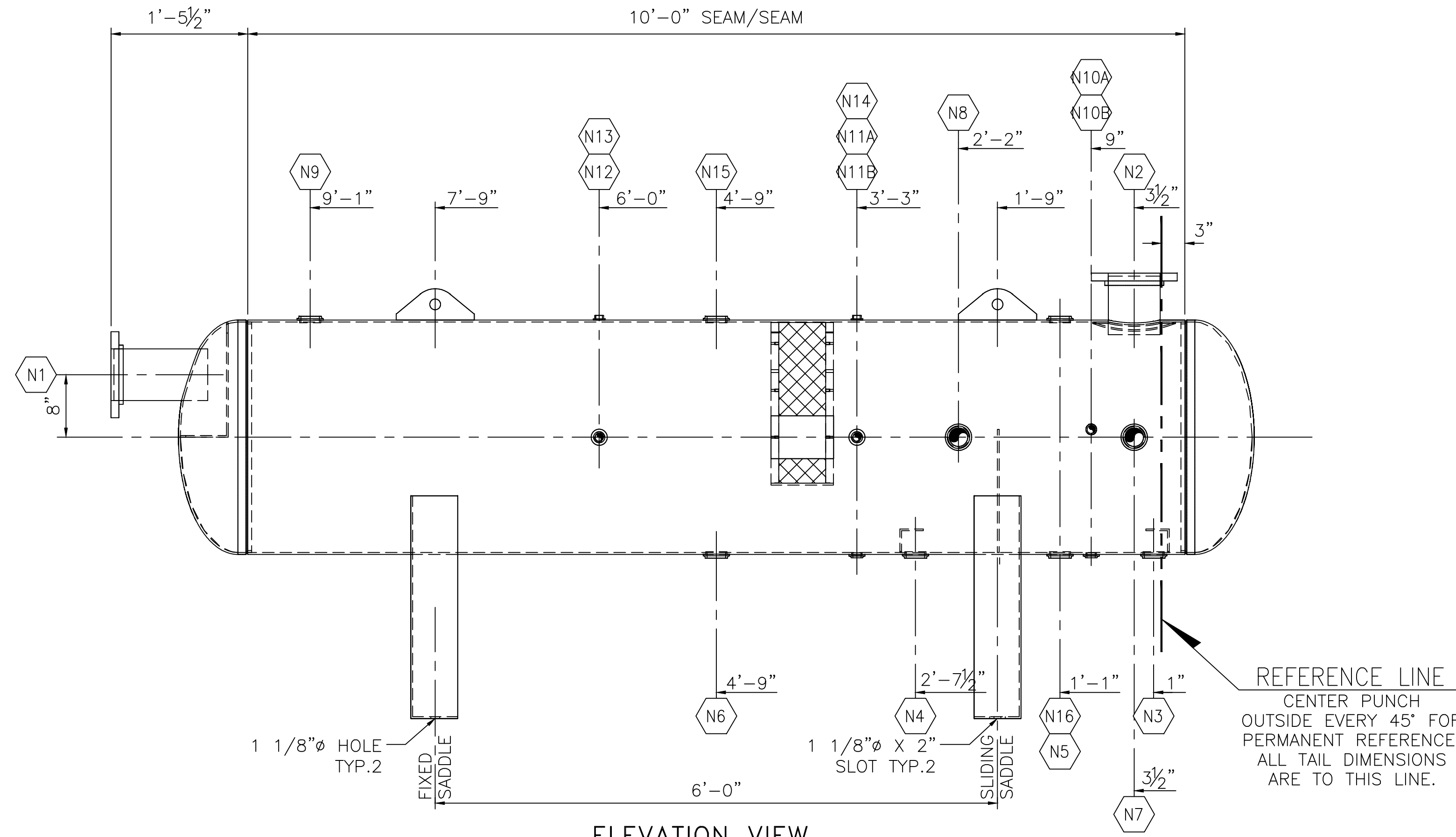

ELEVATION VIEW
SCALE 1" = 1'-0"

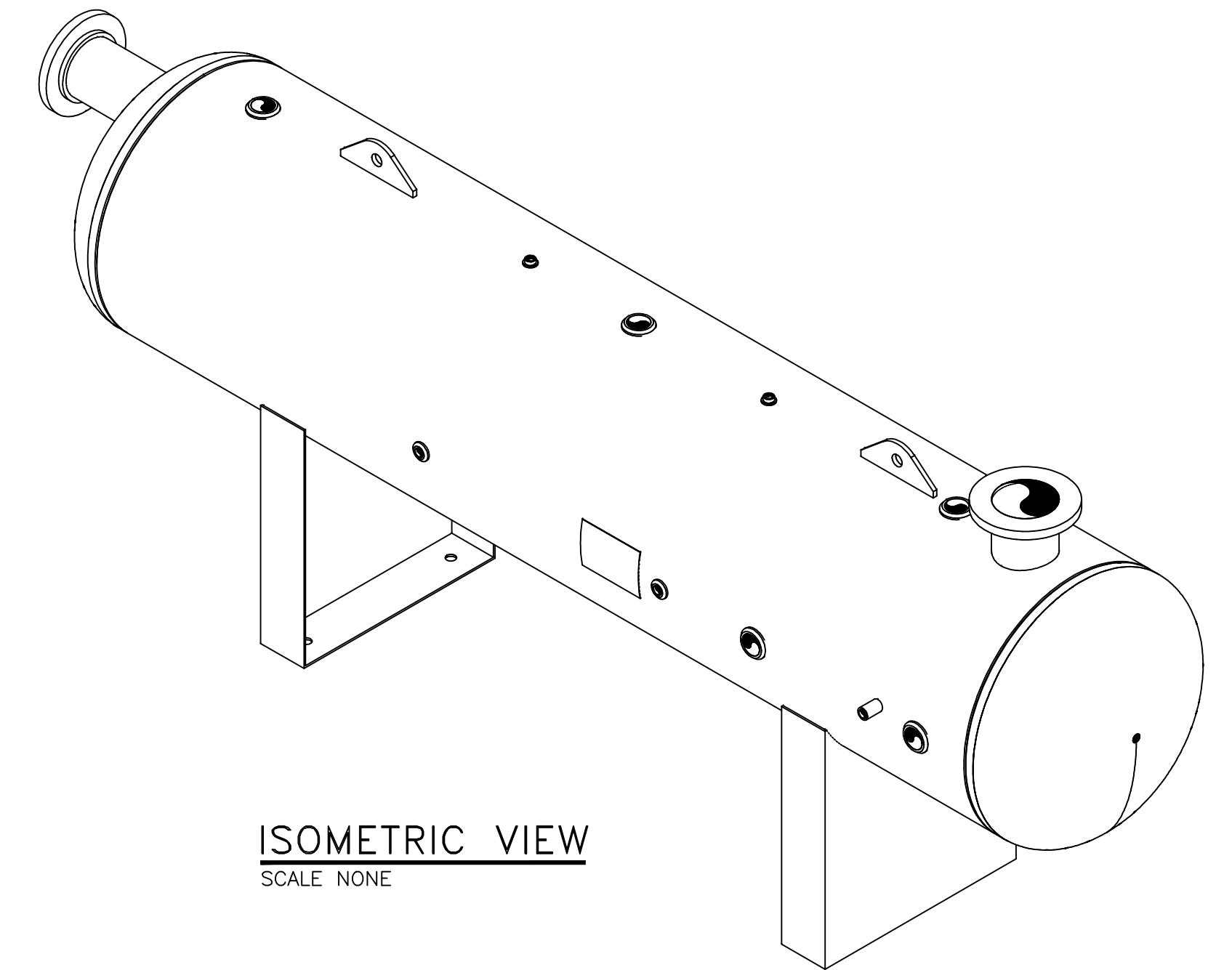

ISOMETRIC VIEW
SCALE NONE

MARK	REQ'D.	SIZE	RATING & TYPE	SERVICE	NECK O.D.	NECK SCH.	O.S. PROJECTION	I.S.	REINF. PAD SIZE	WELDING DETAIL NO.	A	B	C
N16	1	2"	1500# NPT	HLSD	-	-	-	-	-	W13	3/16"	-	-
N15	1	2"	1500# NPT	HLSD	-	-	-	-	-	W13	3/16"	-	-
N14	1	1/2"	1500# NPT	SUPPLY GAS	-	-	-	-	-	W13	3/16"	-	-
N13	1	1/2"	1500# NPT	PRESSURE INDICATOR	-	-	-	-	-	W13	3/16"	-	-
N12	1	3/4"	1500# NPT	TEMPERATURE INDICATOR	-	-	-	-	-	W13	3/16"	-	-
N11B	1	3/4"	1500# NPT	WATER LEVEL GAUGE (LOWER)	-	-	-	-	-	W13	3/16"	-	-
N11A	1	3/4"	1500# NPT	WATER LEVEL GAUGE (UPPER)	-	-	-	-	-	W13	3/16"	-	-
N10B	1	3/4"	1500# NPT	OIL LEVEL GAUGE (LOWER)	-	-	-	-	-	W13	3/16"	-	-
N10A	1	3/4"	3000# CPLG	OIL LEVEL GAUGE (UPPER)	-	-	END	-	-	W14	3/16"	-	-
N9	1	2"	1500# NPT	RELIEF	-	-	-	-	-	W13	3/16"	-	-
N8	1	2"	1500# NPT	WATER LEVEL CONTROLLER	-	-	-	-	-	W13	3/16"	-	-
N7	1	2"	1500# NPT	OIL LEVEL CONTROLLER	-	-	-	-	-	W13	3/16"	-	-
N6	1	2"	1500# NPT	DRAIN/HLSD	-	-	-	-	-	W13	3/16"	-	-
N5	1	2"	1500# NPT	DRAIN/HLSD	-	-	-	-	-	W13	3/16"	-	-
N4	1	2"	1500# NPT	WATER OUTLET	-	-	-	-	-	W13	3/16"	-	-
N3	1	2"	1500# NPT	OIL OUTLET	-	-	-	-	-	W13	3/16"	-	-
N2	1	6"	150# RFSO	GAS OUTLET	6.625"	S/80	6.00"	1.00"	-	W7/W15	3/8"	-	-
N1	1	6"	150# RFSO	INLET	6.625"	S/80	ELEV. 1.00"	-	-	W7/W15	3/8"	3/8"	-

NOZZLE SCHEDULE & WELDING DETAILS

NOZZLE NOTES: 1) DRILL AND TAP 1/4" N.P.T. HOLE IN REINFORCING PADS. 2) INSIDE EDGES OF NOZZLE NECKS SHALL BE ROUNDED TO 1/8" RAD. OR HALF THE WALL THICKNESS IF LESS THAN 1/4". 3) GOUGE, GRIND OR CHIP INSIDE TO SOUND METAL BEFORE MAKING WELD "b". 4) NOZZLE PROJ. ARE FROM SHORT SIDE.

NAMEPLATE DATA

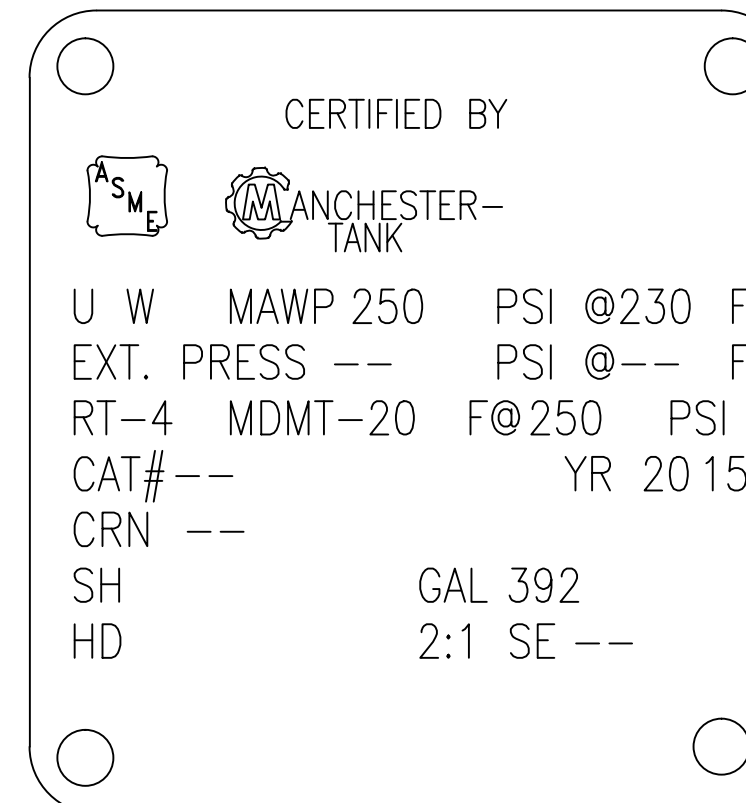

TOTAL WEIGHT = 1,350 LBS.

TOLERANCES
(EXCEPT AS NOTED)
FRACTIONAL
± 1/8"
DECIMAL
± 0.125"
ANGULAR
± 1°

FABRICATION NOTES:

- UNLESS NOTED OTHERWISE, ALL WELDS ARE TO BE 3/16" FILLET WELDS.
- ALL FLANGE BOLT HOLES TO STRADDLE VESSEL CENTERLINES.
- WEIR PLATE TO BE PT TESTED TO ENSURE NO LEAKAGE.
- EACH CONNECTION TO BE TAGGED W/ ABBREVIATION SERVICE DESCRIPTION



THIS DRAWING IS THE PROPERTY OF MANCHESTER TANK AND IS NOT TO BE USED FOR ANY PURPOSE OTHER THAN THAT FOR WHICH IT IS SPECIFICALLY FURNISHED.

CUSTOMER: MANCHESTER TANK

TITLE: HORIZONTAL 3 PHASE LP SEPARATOR
30" OD x 10'-0" S/S @ 250 PSIG
ELEVATION & PLAN VIEW

REV	DESCRIPTION	DATE	BY	CHK	SCALE	REV
A	ISSUED FOR INFORMATION	06/18/15	MCH	JEG	AS NOTED	
REV	DESCRIPTION	DATE	BY	CHK	SCALE	REV