

PLAN VIEW
SCALE 1" = 1'-0"
(TRUE ORIENTATION)

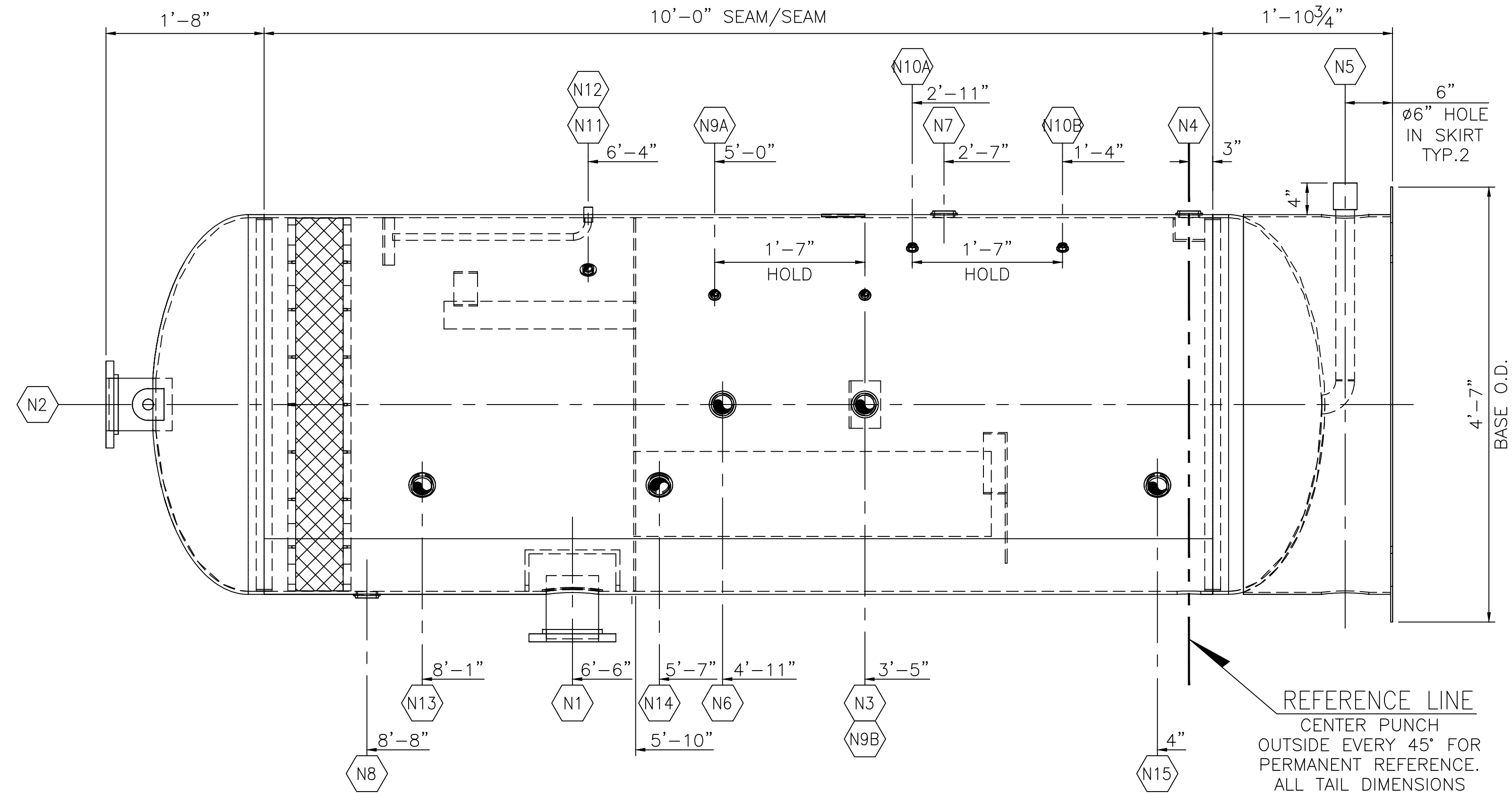

ELEVATION VIEW
SCALE 1" = 1'-0"

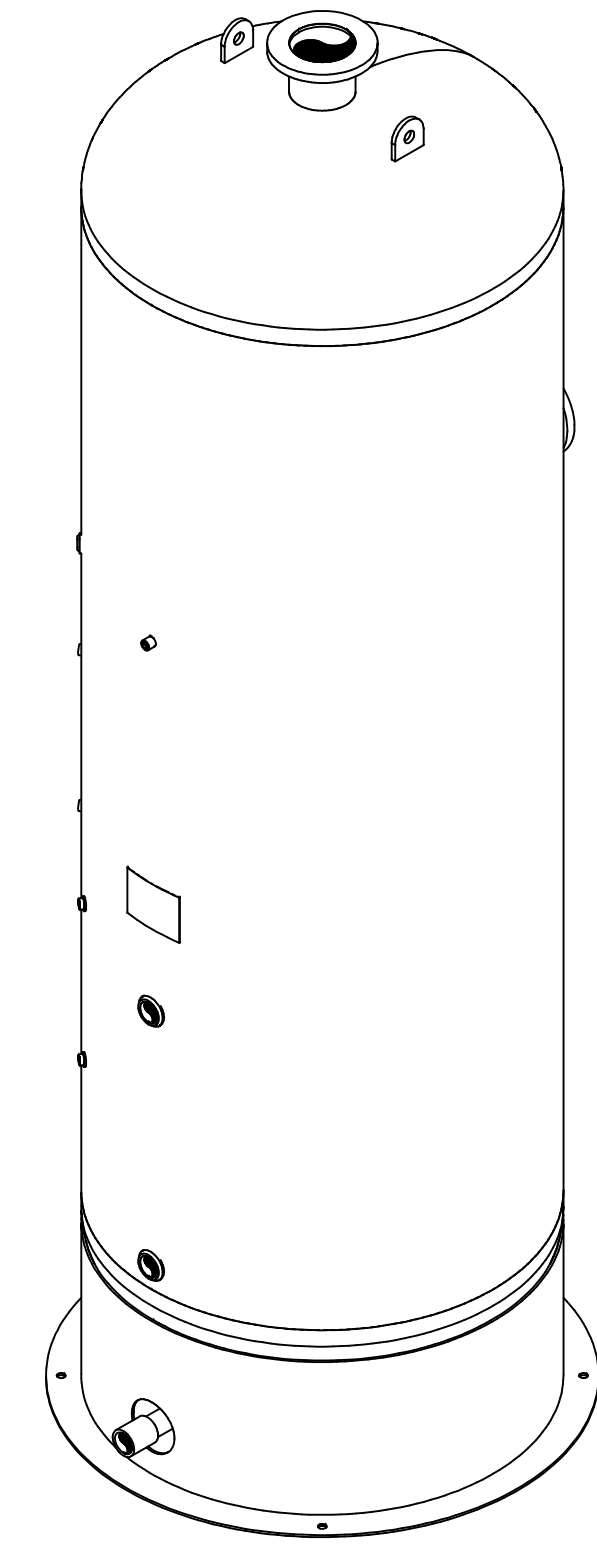

ISOMETRIC VIEW
SCALE NONE

MARK	REQ'D.	SIZE	RATING & TYPE	SERVICE	NECK O.D.	NECK SCH.	O.S. PROJECTION	I.S.	REINF. PAD SIZE	WELDING DETAIL NO.	A	B	C
N15	1	2"	1500# NPT	LIQUID LLSD	-	-	-	-	-	W13	3/16"	-	-
N14	1	2"	1500# NPT	OIL HLSD	-	-	-	-	-	W13	3/16"	-	-
N13	1	2"	1500# NPT	LIQUID HLSD	-	-	-	-	-	W13	3/16"	-	-
N12	1	1/2"	3000# CPLG	PI/SUPPLY	-	-	-	-	-	W14	1/8"	-	-
N11	1	3/4"	1500# NPT	TEMPERATURE INDICATOR	-	-	-	-	-	W13	3/16"	-	-
N10B	1	1/2"	1500# NPT	INTERFACE LEVEL GAUGE (LOWER)	-	-	-	-	-	W13	3/16"	-	-
N10A	1	1/2"	1500# NPT	INTERFACE LEVEL GAUGE (UPPER)	-	-	-	-	-	W13	3/16"	-	-
N9B	1	1/2"	1500# NPT	OIL LEVEL GAUGE (LOWER)	-	-	-	-	-	W13	3/16"	-	-
N9A	1	1/2"	1500# NPT	OIL LEVEL GAUGE (UPPER)	-	-	-	-	-	W13	3/16"	-	-
N8	1	2"	1500# NPT	RELIEF	-	-	-	-	-	W13	3/16"	-	-
N7	1	2"	1500# NPT	INTERFACE LEVEL CONTROLLER	-	-	-	-	-	W13	3/16"	-	-
N6	1	2"	1500# NPT	OIL LEVEL CONTROLLER	-	-	-	-	-	W13	3/16"	-	-
N5	1	2"	3000# CPLG	DRAIN	-	-	FLUSH	-	-	W3	1/8"	-	-
N4	1	2"	1500# NPT	WATER OUTLET	-	-	-	-	-	W13	3/16"	-	-
N3	1	2"	1500# NPT	OIL OUTLET	-	-	-	-	-	W13	3/16"	-	-
N2	1	6"	150# RFSO	GAS OUTLET	6.625"	S/80	ELEV. 1.00"	-	-	W7/W15	3/8"	3/8"	-
N1	1	6"	150# RFSO	INLET	6.625"	S/80	6.00"	1.00"	-	W7/W15	3/8"	-	-

NOZZLE SCHEDULE & WELDING DETAILS

NOZZLE NOTES: 1) DRILL AND TAP 1/4" N.P.T. HOLE IN REINFORCING PADS. 2) INSIDE EDGES OF NOZZLE NECKS SHALL BE ROUNDED TO 1/8" RAD. OR HALF THE WALL THICKNESS IF LESS THAN 1/4". 3) GAUGE, GRIND OR CHIP INSIDE TO SOUND METAL BEFORE MAKING WELD "b". 4) NOZZLE PROJ. ARE FROM SHORT SIDE.

NAMEPLATE DATA

CERTIFIED BY

 U W MAWP 250 PSI @230 F
 EXT. PRESS -- PSI @ -- F
 RT-4 MDMT-20 F@250 PSI
 CAT# -- YR 2015
 CRN --
 SH GAL 1031
 HD 2:1 SE --

TOTAL WEIGHT = 3,500 LBS.

TOLERANCES (EXCEPT AS NOTED)

FRACTIONAL ± 1/8"
 DECIMAL ± 0.125"
 ANGULAR ± 1°

FABRICATION NOTES:

- UNLESS NOTED OTHERWISE, ALL WELDS ARE TO BE 3/16" FILLET WELDS.
- ALL FLANGE BOLT HOLES TO STRADDLE VESSEL CENTERLINES.
- EACH CONNECTION TO BE TAGGED W/ ABBREVIATION SERVICE DESCRIPTION



THIS DRAWING IS THE PROPERTY OF MANCHESTER TANK AND IS NOT TO BE USED FOR ANY PURPOSE OTHER THAN THAT FOR WHICH IT IS SPECIFICALLY FURNISHED

CUSTOMER: MANCHESTER TANK

TITLE: VERTICAL 3 PHASE LP SEPARATOR
 48" OD x 10'-0" S/S @ 250 PSIG
 ELEVATION & PLAN VIEW

REV	DESCRIPTION	DATE	BY	CHK
A	ISSUED FOR INFORMATION	06/18/15	MCH	JEG
REV	DESCRIPTION	DATE	BY	CHK

DRW. NO.	DATE	CHK. BY	DATE	SCALE
309765-S	06/18/15	JEG	06/18/15	AS NOTED